

# 3-Axis Ultrasonic Anemometer



## Key Features

- Precision 3-axis sonic anemometer
- 20Hz Output Rate (32Hz Optional)
- 0-45m/s wind speed
- 0-359° wind direction
- U, V, W Vector Outputs
- Aluminium/Carbon Fibre Construction
- Sonic temperature output
- Optional custom calibration

The Gill WindMaster is a precision anemometer offering three-axis wind measurement data. This instrument will monitor wind speeds of 0-45m/s and provides sonic temperature, speed of sound and U, V & W vector outputs at 20Hz (32Hz optional). This anemometer is of aluminium/carbon fibre construction and is ideal for the understanding of turbulent flows, surface energy balance and scalar fluxes. Each WindMaster is calibrated with a Gill wind tunnel test to provide optimum performance.

This 3D sonic anemometer is ideally suited to the measurement of air turbulence around bridges, buildings, wind turbine sites, building ventilation control systems, meteorological and flux measurement sites.

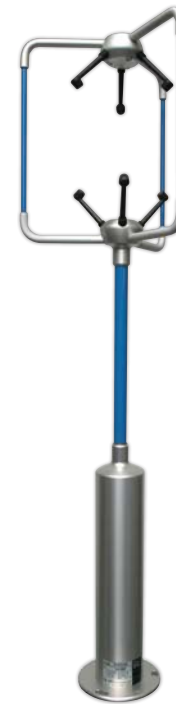

### Wind Speed

Range	0 - 45 m/s
Resolution	0.01 m/s
Accuracy*	<1.5% RMS @12 m/s
Accuracy*	<1% RMS @12 m/s (Custom)

### Direction

Range	0 - 359°
Resolution	0.1°
Accuracy	2° @12 m/s
Accuracy	0.5° @12 m/s (Custom)

### Sonic Temperature

Range	-40°C to +70°C
Resolution	0.01°C

### Speed of Sound

Range	300-370 m/s
Resolution	0.01 m/s
Accuracy	< ±0.5% @ 20°C

### Measurement

Internal sample rate	20 Hz or 32 Hz
Output Parameters	1, 2, 4, 8, 10, 16, 20 & 32 (Option) Hz
Units of Measure	m/s, mph, kph, knots, ft/min
Formats	UVW, Polar or NMEA
Averaging	Flexible 0-3600 s

\*Accuracy spec applies for wind speed, and for wind incidence up to ±30° from the horizontal

### Digital Output

Communication	RS232, 422, 485
Baud Rates	2400 - 115200
Format	ASCII

### Analogue Outputs - Optional

Resolution 12 bits or 14 bits	4 channels available
Selectable Range	User selectable full scale wind speed
Output type	0-20mA, 4-20mA, 0-5 V, ±2.5 V, ±5 V

### Analogue Inputs - Optional

Resolution 12 bits or 14 bits	Up to 4 single ended or 2 differential
Input Type	±5 V

### Power Requirement

Anemometer	9-30 VDC (25mA @ 12 VDC)
------------	--------------------------

### Mechanical

Weight	1.0 kg
Size	750mm x 240mm

### Environmental

Protection Class	IP65
Operating Temp	-40°C to +70°C
Humidity	< 5% to 100% RH
Precipitation	300mm/hr
EMC	BS EN 61000 - 6 - 3 (Emissions) BS EN 61000 - 6 - 2 (Immunity)

## 3-Axis Ultrasonic Anemometer

### Typical Applications

- Power Lines
- Bridges
- Viaducts
- Building ventilation control systems
- Measurement Masts
- Skyscrapers
- Wind Turbine Test Sites
- Meteorological & Flux measurement sites

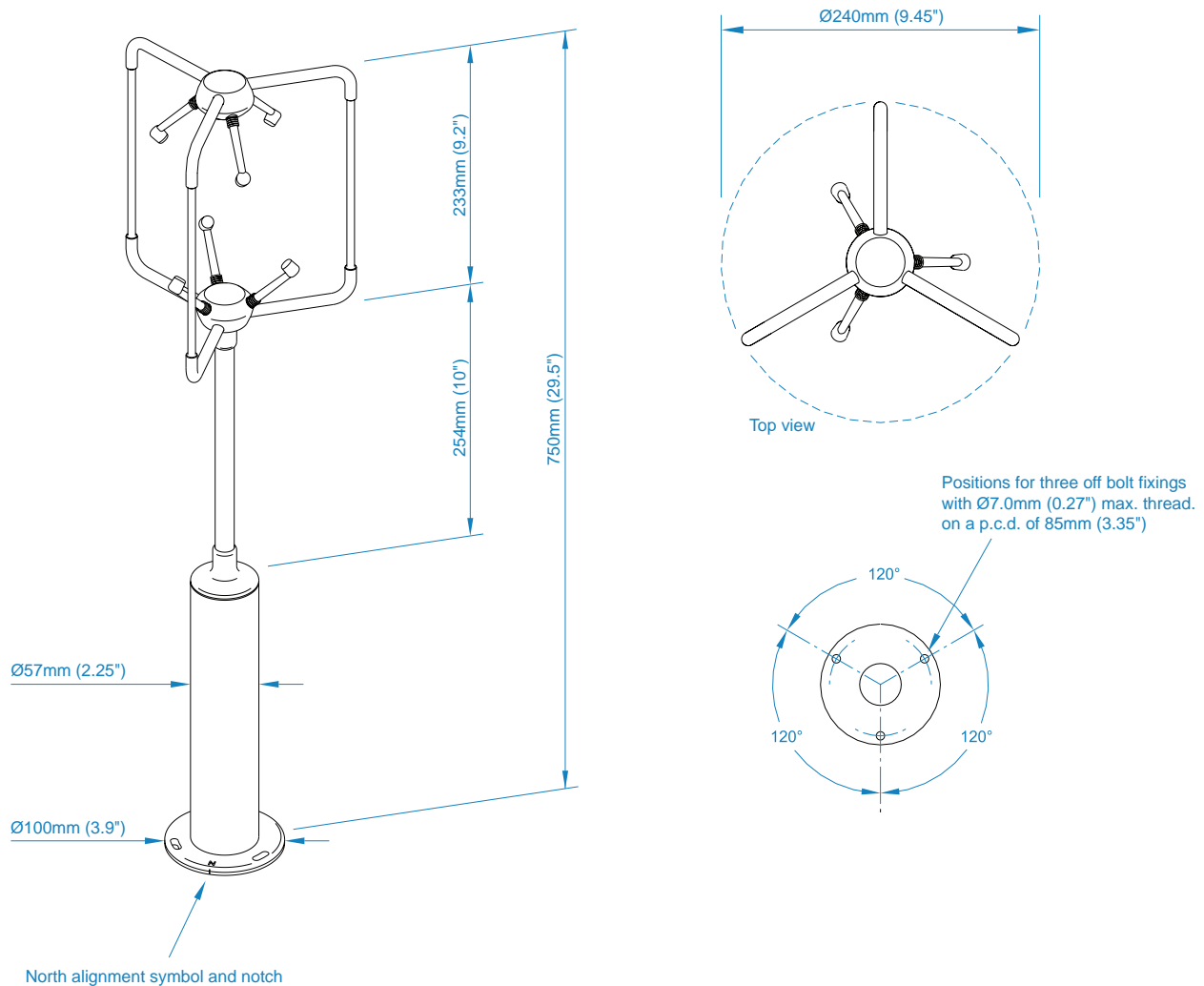

This product is in continuous development and therefore specifications may be subject to change without prior notice.



**Gill Instruments Ltd**  
Saltmarsh Park  
67 Gosport Street  
Lymington  
Hampshire  
SO41 9EG, UK

T: +44 (0) 1590 613 500  
F: +44 (0) 1590 613 555  
E: [anem@gill.co.uk](mailto:anem@gill.co.uk)

[www.gill.co.uk](http://www.gill.co.uk)



Copyright © Gill Instruments 2011

D1304 - Iss 1

Gill Instruments Ltd

Reg No. 3154453 Registered Office: The George Business Centre, Christchurch Road, New Milton, BH25 6QJ