



Horizontally Symmetrical Research Ultrasonic Anemometer

User Manual

Doc No. 1199-PS-0003

Issue 08

**Anemometer Software Version 2.xx
PC Software (RCOM) - Software Version 3.xx**

Gill Instruments Limited

Saltmarsh Park,
67 Gosport Street,
Lymington,
Hampshire.
SO41 9EG
UK

Tel: +44 (0) 1590 613500

Fax: +44 (0) 1590 613501

E-mail: anem@gill.co.uk

Website: www.gill.co.uk



1. FOREWORD.....	5
2. SYSTEM INSTALLATION	6
2.1 Mounting	6
2.2 Alignment	6
2.3 Using the Inclinometer	6
2.4 Corrosion	6
2.5 Earthing	6
2.6 Cabling	6
3. SYSTEM OPERATION.....	7
3.1 Overview	7
3.2 Operating modes.....	7
3.3 Measurement Mode	7
3.4 Sampling.....	7
3.5 Averaging	7
3.6 Wind Measurement, SoS and Temperature Reporting Format.....	8
3.7 Analogue Input Reporting Formats	8
3.8 Diagnostics	8
3.9 Confidence Tone	9
3.10 Result Reporting.....	9
3.11 Interactive Mode.....	9
3.12 Configuration Commands.....	9
3.13 Interrogation Commands	9
4. CONNECTION TO A PC OR OTHER DEVICE.....	10
5. USING THE ANEMOMETER WITH A PC RUNNING RCOM	11
5.1 PC Requirement.....	11
5.2 Installing RCOM	11
5.3 Starting RCOM.....	11
5.3.1 Command line options	11
5.3.2 Procedure if no anemometer is found.....	12
5.4 Main Menu	12
5.5 Trend Display	13
5.6 Trend Options	13
5.7 Display Micro-met Parameters	13
5.8 Micro-met Parameter Options	13
5.9 Tabular Display	13
5.10 Configure Anemometer	13
5.11 Options	13
5.12 Exit to DOS	14
5.13 Trend Display	14
5.14 Display Micro-met Parameters	15
5.15 Micro-met Parameter Options	16
5.16 Tabular Display	17
5.17 Configure Anemometer	18
5.18 Options	19
5.19 Storage of settings	20
5.20 RCOM Error Messages	20
5.21 Instructions For Using The Convert 3 Binary To ASCII Conversion Utility	21
6. USING THE ANEMOMETER WITH A PC RUNNING YOUR SOFTWARE	21
6.1 Digital Serial Output Format	20
6.1.1 Binary Result Message Format.....	22
6.1.2 ASCII Result Message Format	23
6.1.3 Status Fields.....	24
6.1.4 Software commands	26
7. USING THE ANALOGUE INPUTS OF THE ANEMOMETER	32
8. USING THE PRT INPUT	33
9. USING THE ANALOGUE OUTPUTS	34

9.1 Introduction	34
9.2 Analogue outputs.....	34
9.3 Analogue Sync. Output.....	34
9.4 Status Output	34
9.5 Test Modes	34
10. DRAWINGS.....	35
1086-M-043 Anemometer Cable (Voltage Out).....	36
1189-K-022 Indoor PCI Unit Dimensions.....	37
1199-K-066 3 Axis Horizontal Anemometer U,V &W Axis Definitions	38
1199-K-089 3 Axis Horizontal Anemometer Head + Electronics Mounting Details	39
1210-K-068 R3 & HS Research Anemometer Measurement Sequence.....	40
Assembly of Amphenol C91A Screw Lock 4 Way Socket	41
11. TECHNICAL SPECIFICATION	42
11.1 Wind Measurement.....	42
11.2 Speed of Sound Measurement	42
11.3 Environmental	42
11.4 Supply Input	42
11.5 Serial Interface.....	42
11.6 Analogue Inputs.....	43
11.7 PRT.....	43
11.8 Anemometer Sync Output	43
11.9 Inclinometer.....	43
11.10 Anemometer Power and Data Connector Hirose 20 way socket	43
12. POWER AND COMMUNICATIONS INTERFACE.....	44
12.1 Desk Top PCI	44
12.2 Connector Pin Assignments.....	44
12.3 PCI Specification.....	46
APPENDIX A	48
SUMMARY OF ABBREVIATIONS USED IN THIS MANUAL.....	48
PACKING LIST.....	48
OPTIONAL EXTRAS.....	48
APPENDIX B.....	49
Principle of Operation	49
APPENDIX C.....	50
Sonic Temperature Measurement	51
APPENDIX D	58
Micro-Met Calculations.....	59
APPENDIX E.....	65
RCOM Binary File Format.....	65

1. FOREWORD

This manual refers to the Gill Instruments Ltd. Horizontally Symmetrical Research Ultrasonic Anemometer. It is an extremely sophisticated instrument and to achieve optimum performance we recommend that you read the whole of this manual before proceeding further with use.

The Solent Range is in continuous development and so specifications may be subject to change without prior notice.

2. SYSTEM INSTALLATION

2.1 Mounting

The head and electronics unit should be mounted in accordance with Drawing Number 1199-K-089.

2.2 Alignment

It is recommended that the head is aligned so that the upper transducer sphere is directly above the lower transducer sphere. The inclinometer has been calibrated to read zero on both axes when this position is reached.

2.3 Using the Inclinometer

The data from the inclinometer can be obtained in several ways:

- a) RCOM displays this information at the bottom of the screen
- b) By typing INCL in interactive mode (see Section 6).
- c) By decoding the upper status addresses of the anemometer output message (see Section 6).

2.4 Corrosion

Galvanic corrosion is possible unless stainless steel fixings are used for mounting the head and electronics unit. This will ensure that the anemometer will provide long service under extreme conditions e.g. marine.

2.5 Earthing

For maximum protection against lightning the head must be earthed via its mountings. The electronics unit and PCI should be earthed using the earth studs provided.

2.6 Cabling

Ensure that strain relief measures are employed when installing the anemometer cables. Do not allow the whole weight of a cable to be applied to the connector.

3. SYSTEM OPERATION

3.1 Overview

- Data output rates up to 100s^{-1} .
- Measurement of wind velocities in excess of 30ms^{-1} .
- Wind speed accuracy $< 1\%$ RMS.
- Accurate speed of sound measurement.
- Configuration carried out via serial port and stored in non-volatile memory.
- High speed, full duplex RS422 interface, operating up to 115200 baud.
- Background diagnostics providing the user with the confidence that the unit is operating correctly.
- 6 differential 14 bit analogue inputs and one PRT100 input.
- Analogue outputs representing wind speed, SoS, and temperature optionally fitted in PCI.

3.2 Operating modes

The anemometer has two operating modes:

1. Measurement mode - This is the normal mode of operation, which is the default mode from power up.
2. Interactive mode - This allows the anemometer to be configured and interrogated.

3.3 Measurement Mode

The principle of operation is described in Appendix B. The parameters sampled are determined by the anemometer's configuration and consist of:

1. Wind velocity (axis velocities are always sampled)
2. Speed of Sound (SoS)
3. Analogue Inputs (6)
4. Absolute Temperature (PRT100).

The way in which the results are calculated, formatted and reported depends upon the configuration of the anemometer.

3.4 Sampling

Wind velocity, SoS and analogue inputs are sampled every 10ms, in a fixed sequential pattern. The PRT100 is sampled every 40ms. The measurement sequence is shown in Drawing Number 1210-K-068.

3.5 Averaging

These samples are block averaged before being converted into results. For wind speed, SoS and analogue inputs the number of samples used in the block average can be set to between 1 and 250 samples. The corresponding maximum number of PRT100 samples per result is 62.

3.6 Wind Measurement, SoS and Temperature Reporting Format

The wind measurement can be output in one of the following formats:

1. U, V & W, calibrated (ms^{-1})
2. U, V & W, uncalibrated (ms^{-1})
3. Polar & W, calibrated ($^{\circ}$ & ms^{-1})
4. Polar & W, uncalibrated ($^{\circ}$ & ms^{-1})
5. Axis velocities, uncalibrated (ms^{-1})

In U, V,W modes the alignment of the U and V axes can be selected as follows:-

Axis U in line with Axis 1 when the anemometer is viewed from above.

Spar U is in line with the main spar when viewed from above. In this configuration U, V, W are labelled U', V', W'.

The U, V, W axis alignment options are shown in the relevant U, V, W axis definition drawing in Section 10.

The axis alignment can be selected using the Configuration menu within RCOM (Section 5.17) or the ALIGNUVW command if using your own PC software (Section 6.1.4).

The speed of sound measurement results can be output in one of the following formats:

1. Speed of Sound (ms^{-1})
2. Sonic Temperature (K)
3. Sonic Temperature ($^{\circ}\text{C}$)

Speed of sound measurements can be disabled.

The absolute temperature measurement results can be output in one of the following formats:

1. Absolute Temperature (K)
2. Absolute Temperature ($^{\circ}\text{C}$)

Absolute temperature measurements can be disabled.

3.7 Analogue Input Reporting Formats

If ASCII format is selected, analogue input measurements are output in volts to 4 decimal places. If binary format is selected, analogue input measurements are output in 2's complement.

The number of analogue inputs to be measured can be set from 0 to 6.

3.8 Diagnostics

The system reports error codes if a failure is detected of the ultrasonic transducers, non-volatile memory or PRT.

3.9 Confidence Tone

If this function is enabled then normal operation is indicated by an intermittent tone within the anemometer.

3.10 Result Reporting

The selected parameters are blocked together along with the diagnostic results and block control information to form a result message. The result message can either be in a Binary or ASCII format. In the ASCII format the fields can be padded to form a fixed field size if required. The way the result message is transmitted is dependant on the reporting mode:

1. Continuous mode - the result message is transmitted immediately after calculation.
2. Polled mode - the host pc requests data from the anemometer. The anemometer responds by sending the current result message.

3.11 Interactive Mode

Interactive mode is entered from measurement mode, by sending the anemometer the appropriate command. In this mode the user can communicate with the anemometer, issuing configuration commands to the anemometer, or requesting information from the anemometer.

3.12 Configuration Commands

Configuration commands allow the user to configure the anemometer as required. The configuration parameters are held in non-volatile storage, allowing the anemometer to retain it's current configuration when powered down.

3.13 Interrogation Commands

Interrogation commands allow the user to request various information from the anemometer.

4. CONNECTION TO A PC OR OTHER DEVICE

Connection to a PC or other device requires the use of:

1. Either a standard PCI
2. Or a suitable alternative power supply and RS422 conversion unit, which meets the specification of the anemometer.

2 cables will be required:

1. Anemometer EU to PCI
2. PCI to PC - RS232 or RS422

The PCI supplies power for the anemometer and provides conversion of the RS422 signal sent by the EU and the RS232 signal required by a PC. The PCI requires connection to a mains power supply or DC. Computers other than IBM PC's or compatibles may require a customised cable for connection to the PCI.

The anemometer outputs data through a connector on the EU. Data is provided in RS422 format only and reconstituted to analogue if required at the PCI.

Baud rate options are:

1. 2400
2. 4800
3. 9600
4. 19200
5. 38400
6. 57600
7. 115200

Data format:

1. 8 data, 1 stop, no parity.

5. USING THE ANEMOMETER WITH A PC RUNNING RCOM

5.1 PC Requirement

Minimum 286, VGA and 1Mb of RAM
Recommended 486 DX2 66MHz.

5.2 Installing RCOM

The RCOM program and its auxiliary files are stored on a single 3½" disk. They should be installed on the hard disk in a directory named \RCOM. To install the software type the following commands in this order. For the user settings within RCOM to be stored correctly the RCOM directory must be in the root e.g. C:\RCOM.

```
MD C:\RCOM
COPY A:*. * C:\RCOM
```

NB This assumes that your 3½" drive is drive A: and your hard disk is drive C:. If not replace A: and C: in the above commands with the drive letters for your 3½" and hard disk drives respectively.

5.3 Starting RCOM

To start the RCOM Program, change directory to the RCOM directory and type RCOM.

```
CD \RCOM
RCOM
```

RCOM may be followed by one or more command line options. The PC will search on its serial link for an anemometer. When an anemometer is found the main menu is displayed.

5.3.1 Command line options

The RCOM program may be passed one or more command line parameters.

/C_n Sets the COM port to use for the anemometer. Valid settings are n = 1, 2, 3 or 4. Default is COM1.

/CB_n Serial port base address. If your PC has non-standard serial ports, it may be necessary to set the base address of the port. Usually the PC can work this out from the COM port, so this command should only be needed in rare circumstances. For instance, to set the base address to 2F8h use the command line option /CB02F8.

/CI_n Serial port interrupt number. Sets the interrupt (IRQ) number used by the COM port. Usually this is standard for COM1 and COM2 (IRQ4 and IRQ3 respectively). There is no generally accepted defaults for COM3 and COM4. Therefore this command should only be necessary if you intend to use COM3 or COM4, or if you have a non-standard COM1 or

COM2. For example to instruct RCOM to seek an anemometer on COM3 using interrupt 4 the command would be:

RCOM /C3 /CI4

5.3.2 Procedure if no anemometer is found

If no anemometer is found then the program displays the following menu.

RCOM	Gill Instruments Ltd
WARNING! No anemometer found	
Please ensure that the anemometer is connected And that power is available	
1. Search for Anemometer Again	
2. Change Serial Port (COM2)	
3. Change Base Address 02F8h	
4. Change Interrupt vector 03h	
5. Exit	

The user should:

1. Ensure that the anemometer is connected and powered up. If you are using an indoor Power and Communications Interface (PCI) and the RX LED is flashing then the anemometer is powered up and communicating. If the RX LED is NOT flashing it DOES NOT imply that the anemometer has no power, the anemometer may be awaiting a command over the serial link.
2. Check that the COM port displayed (COM2 in the above example) is correct. If not select option 2 on the menu and select the correct comms port.
3. Select option 1 on the menu. The software will seek the anemometer again. If you are using an indoor Power and Communications Interface (PCI), the TX LED should flash during this process. If it does not then either the serial port setting is wrong or there is a problem with the communication cable between the PC and the PCI.
4. If the anemometer is still not found then check that the settings of base address and interrupt vector are correct for your PC. If not use options 3 & 4 to correct them and option 1 to repeat the search for the anemometer.

5.4 Main Menu

The main menu allows the selection of primary functions.

1. RCOM V1. 01	Gill Instruments Ltd
1. Trend Display	
2. Trend Options	
3. Display Micro-met Parameters	
4. Micro-met Parameter Options	
5. Tabular Display	
6. Configure Anemometer	
7. Options	
8. Exit to DOS	

5.5 Trend Display

This provides a graphical display of wind component trends. Raw data can be written to disk. (See Section 5.14)

5.6 Trend Options

This allows the user to select which parameters to display on the trend display, and to select super-VGA modes. The software supports 800x600 and 1024x768, 16-colour modes on VESA compatible super-VGA cards.

5.7 Display Micro-met Parameters

This displays micro-meteorological parameters in real time. Raw data and calculated parameters can be written to disk. (See Section 5.14)

5.8 Micro-met Parameter Options

This allows the user to select which micro-meteorological parameters to display and which micro-meteorological parameters to download to disk. (See Section 5.15)

5.9 Tabular Display

This gives a scrolling display of wind measurement. Maximum and minimum values can be displayed. Raw data can be written to disk. (See Section 5.16)

5.10 Configure Anemometer

This displays the configuration of the anemometer and allows the user to alter parameters. (See Section 5.17)

5.11 Options

This allows the user to set various options. These are mostly to do with writing data to disk. (See Section 5.18)

5.12 Exit to DOS

This quits the program and returns the user to the operating system.

5.13 Trend Display

The Trend Display provides a graphical display of wind component trends. Each parameter is displayed on its own set of axes and in a unique colour. The labels on the Y-axis give the name of the parameter and the scale. The data is displayed from left to right. Each sample is displayed as a separate pixel, therefore the speed of the display and the resolution of the X-axis is dependent on the sample rate and the resolution of the screen. The X axis is labelled in seconds. When the extreme right of the screen is reached the colour of the old data changes to grey, and the scale is displayed on the right in grey. The display then starts again from the left-hand edge, with new scale values.

U, V, W and magnitude are displayed in m.s^{-1} . Direction is displayed in degrees. Temperatures are displayed either in Kelvin or degrees Celsius. Analogue inputs are in volts. Each display is scaled individually. In the example below the W vector is scaled at $\pm 5\text{m.s}^{-1}$ whilst U and V are scaled at $\pm 2\text{m.s}^{-1}$.

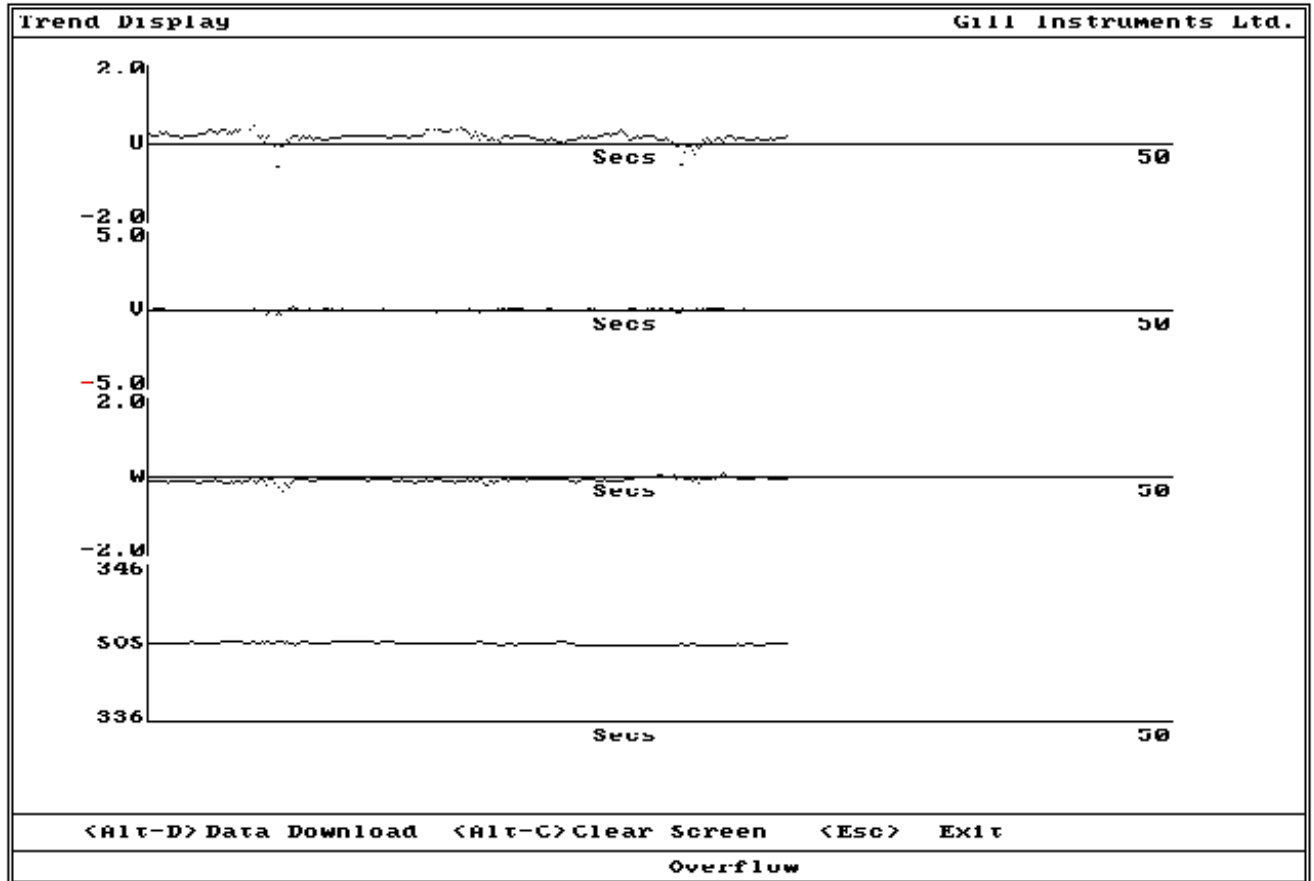

Pressing the “Alt” and “D” keys simultaneously (Alt-D) will initiate a data download. The user will be asked for a filename and the raw data will be written to that file. The format of the download is selected from the Options Menu. Once a data display has been started the Alt-D combination will stop the download without ending the display.

Pressing the “Alt” and “C” keys simultaneously (Alt-C) will clear the screen and start the data display from the left, with new scale values. Pressing the “Esc” key will stop any download that is in progress, terminate the display and return the user to the main menu.

5.14 Display Micro-met Parameters

Micro-met Parameters screen displays micro-meteorological parameters in real time. The results displayed are selected and the time over which they are calculated is set in the Micro-met options menu. The calculations performed are described in Appendix B.

Calculated parameters can be written to disk. The results saved are selected in the Micro-met options menu and are independent of the results displayed.

Pressing the “Alt” and “D” keys simultaneously (Alt-D) will initiate a data download. The user will be asked for a filename and the selected calculated parameters will be written to

that file. The format of the download is selected from the Options Menu. Once a data display has been started the Alt-D combination will stop the download without ending the display.

Pressing the “Alt” and “C” keys simultaneously (Alt-C) will clear the screen and re-start the display.

Pressing the “Esc” key will stop any download that is in progress, terminate the display and return the user to the main menu.

The example screen shows what would be displayed with mean and standard deviation; U, V and W; covariance of U with V; covariance of U with W; covariance of V with W; U* and Cd selected for display. Pressing the “Esc” key exits this display and returns to the main menu.

Micro-met Parameters		Gill Instruments Ltd
Mean U	+0.168 m/s	
Mean V	-0.001m/s	
Mean W	-0.140 m/s	
U _{sig}	+0.237 m/s	
V _{sig}	+0.166 m/s	
W _{sig}	+0.087 m/s	
UV _{cov}	+0.024 m ² /s ²	
UW _{cov}	-0.003 m ² /s ²	
VW _{cov}	+0.002 m ² /s ²	
U*	+0.000 m/s	
Cd	+0.000	
<Alt-D> Data Download		<Alt-C> Clear Screen
		<Esc> Exit
		Status OK

5.15 Micro-met Parameter Options

This allows the user to select which micro-meteorological parameters to display and which micro-meteorological parameters to download to disk. It also allows the setting of various user defined parameters. The calculations performed to derive these parameters are contained in Appendix B.

For each parameter there are two entries. Each may be either a tick or a cross. If the entry under the ‘Disp’ label is a tick then that parameter will be displayed on the micro-met parameters screen. If the entry under the ‘Log’ label is a tick then that parameter will be written to disk.

Selecting Von Kármán Constant, Specific Density of Air, Specific Heat of Air, Gravity Constant or Sample Time allows the user to edit these settings. The Temperature Input setting allows sonic temperature or absolute temperature from the PT100 to be used as the input parameter T. The example screen shows what would be displayed with means of U, V and W; covariance of U with V, covariance of U with W and covariance of V with W

selected for display and the means U, V and W selected for download to disk. Selecting Exit or pressing the “Esc” key exits this menu and returns to the main menu.

6. Micro Meteorology Options					Gill Instruments Ltd			
Means		Natural Stand Devs			Input Means			
	Disp Log		Disp Log					
Mean U	✓	✓	xsig	X	X	Alp 1	X X	
Mean V	✓	✓	ysig	X	X	Alp12	X X	
Mean W	✓	✓	zsig	X	X	Alp3	X X	
Mean T	X	X				Alp4	X X	
		Turbulence Parameters			Alp5			
Stnd Devs		Disp Log						
	Disp Log		tx	X	X			
Usig	X	X	ty	X	X	Input Stnd Devs		
Vsig	X	X	tz	X	X	Disp Log		
Wsig	X	X	u*	X	X	Alp1sig	X X	
Tsig	X	X	T*	X	X	Alp2sig	X X	
		Cd			X	X	Alp3sig	X X
Covariances		L			X	X	Alp4sig	X X
	Disp Log		F	X	X	Alp5sig	X X	
Uvcov	✓	X	Qh	X	X	Alp6sig	X X	
Uwcov	✓	X	TKE	X	X			
Vwcov	✓	X						
UTcov	X	X	Input Covariances					
VTcovX	X		Disp Log					
WTcov	X	X	AlpWcov					
User Parameter		Alp2Wcov						
Von Karman Constant			0.40			Alp3Wcov		
Specific Density of Air			1.225			Alp4Wcov		
Specific Heat of Air			1004.67			Alp5Wcov		
Gravity Constant			9.80			Alp6Wcov		
Sample Time (Minutes)			60			Exit		
Use Temperature Input Sonic Temp								

5.16 Tabular Display

This gives a scrolling display of wind measurement. The oldest results are at the top of the screen. New results are added at the bottom of the screen and the whole display is scrolled upwards. If all the options are turned on then the amount of data will exceed the screen width. In this instance the number of decimal places used to display the analogue inputs will be reduced. The data written to disc will use all decimal places and may therefore exceed eighty characters.

Maximum and minimum values can be displayed at the bottom of the screen. Maximum and minimum are selected from the options menus. The maximum and minimum display can be cleared by pressing “Alt-M”.

Raw data can be written to disk. Pressing the “Alt” and “D” keys simultaneously (Alt-D) will initiate a data download. The user will be asked for a filename and the raw data will be written to that file. The format of the download is selected from the Options Menu. Once a data display has been started the Alt-D combination will stop the download without ending the display.

Pressing the “Alt” and “C” keys simultaneously (Alt-C) will clear the screen and start the data display from the top of the screen. It does not clear the maximum and minimum display. Pressing the “Esc” key will stop any download that is in progress, terminate the display and return the user to the main menu.

Data Display				Gill Instruments Ltd	
Sa	Sb	U	V	W	SoS
04	00	+00.00	+00.00	-00.02	288.76
05	00	+00.00	+00.00	-00.02	288.76
06	01	+00.00	+00.00	-00.02	289.01
07	31	+00.00	+00.00	-00.02	288.78
08	00	+00.00	+00.00	-00.02	288.75
09	00	+00.01	+00.00	-00.02	288.75
0A	00	+00.00	+00.00	-00.03	288.77
01	08	+00.00	+00.00	-00.02	288.76
02	2C	+00.00	+00.00	-00.02	288.74
03	00	+00.00	+00.00	-00.02	288.78
04	00	+00.01	+00.00	-00.01	288.76
05	00	+00.00	-00.01	-00.01	289.04
06	01	+00.00	+00.00	-00.02	288.75
07	31	+00.00	+00.00	-00.03	289.06
08	00	+00.00	+00.00	-00.03	289.04
09	00	+00.00	+00.00	-00.02	288.74
0A	00	+00.00	+00.00	-00.02	288.77
01	08	+00.01	+00.00	-00.01	288.75
02	2C	+00.00	+00.00	-00.03	288.76
03	00	+00.00	+00.00	-00.02	288.77
04	00	+00.01	+00.00	-00.01	288.74
05	00	+00.00	+00.00	-00.02	288.75
01	00	-00.05	-00.39	-00.24	288.72
0A	31	+00.24	+00.01	+00.01	289.30
<Alt-D> Data Download <Alt-C> Clear Screen <Esc> Exit					
Status OK					

5.17 Configure Anemometer

This displays the configuration of the anemometer and allows the user to alter parameters. Selecting any option except “average” causes a small menu to be displayed. This menu offers all the possible settings for that parameter. Selecting “average” allows the user to alter the number of firings averaged by the anemometer. This can be any integer value between 1 and 250.

The example shows the “Message Mode” sub-menu “popped-up” over the configuration screen.

Selecting EXIT or pressing the “Esc” key exits this menu and returns to the main menu

2. Configuration		Gill Instruments Ltd
Serial Number: 0123456		
Data Reported		Reporting Speed
Report Mode	UVW CAL	Average 10
Speed of Sound mode	SPEED	Baud Rate 19200
Absolute Temp Mode	OFF	
		Analogue
String Format		Channels enabled DDDDDD
String Format	BINARY	Full Scale Deflect 30
ASCII Terminator	CRLF	Direction Wrap Mode 360
Echo		
Message Mode	CONT POLL	Additional Features
		Confidence Tone DISABLED
		Axis Alignment AXIS
		EXIT

5.18 Options

This allows the user to set various options. These are mostly to do with writing data to disk.

Selecting “Output Field Separator” allows the user to select what separator will be used in ASCII mode downloads. The choices are Comma, Space, Tab or Semi-Colon. If the download format is set to Binary than this option has no effect.

Selecting “Output Line Terminator” allows the user to select what terminator will be used at the end of lines in ASCII mode downloads. The choices are carriage return (CR) or carriage return and line-feed (CR/LF). If the download format is set to Binary than this option has no effect.

Selecting the "Download format" allows the user to choose whether to store data in ASCII or Binary. ASCII files are suitable for reading into a text editor or spreadsheet directly. They take longer to write and may require more disk space than binary files. Binary data needs to be converted to ASCII by a separate program before reading into a text editor or spreadsheet. The conversion program "Convert 3" is supplied with the anemometer for this purpose. Instructions for Convert 3 are provided in Section 5.21. The binary file format is specified in Appendix E.

“Output Field Separator”, “Output Line Terminator” and “Download format” affect downloads from the trend display, the micro-met parameter display and the tabular display. Selecting “Display Maxima and Minima” toggles the display of maximum and minimum values in tabular display on or off.

Selecting "Output Period" allows the user to enter an averaging period (1 to 60 mins) for use when displaying and logging data in trend and tabular display mode. A time of 0 gives no averaging. Averaging period selected is displayed after the status code.

Selecting Return to Main Menu or pressing the "Esc" key exits this menu and returns to the main menu.

4. Options	Gill Instruments Ltd
1. Output Field Separator	COMMA
2. Output Line Terminator	CR/LF
3. Download Format	ASCII
4. Display Maxima and Minima	On
5. Output Period	0
6. Return to Main Menu	

5.19 Storage of settings

All menu selections that set a parameter are stored in a data file on the hard disk in a file named "\RCOM\MICROMET.SET". This prevents the users from having to re-enter settings each time the program is run. If this file cannot be found then default values will be used and the file created.

5.20 RCOM Error Messages

Transducer pair(s) X failed

One or more transducer pairs (indicated by X) has failed. This may be due to failure of one or both transducers or their associated electronics, or due to a blockage in the ultrasonic path.

Non-volatile memory error

Indicates a failure in the non-volatile EEPROM memory of the anemometer.

Absolute PRT failed

Indicates failure of the PRT temperature probe or its associated electronics

Configuration Mis-match

Indicates that the configuration reported by the status codes in Measurement Mode does not match that reported by the CONFIG command in Interactive Mode.

Anemometer Type Mis-match

Indicates that the anemometer type reported by the status codes does not match the anemometer type indicated by the serial number.

Transducer pair(s) X at n% gain

Indicates that one or more transducer pairs (indicated by X) is at a high gain setting (50, 90 or 100%, indicated by n).

5.21 Instructions For Using The Convert 3 Binary To ASCII Conversion Utility

- Convert 3 is used with RCOM, the Solent R3 and HS research anemometer PC software.
- A binary file is converted to ASCII.
- DOS command line options:-
- `convert3 <input file name> [output file name] [sos|abst|a1...a6|clino|none]`
- If no output file name is specified then the output file name is used with a .CSV file extension.
- The anemometer status and wind data is always converted to ASCII.
- Additional data can be selected as follows:-
 - sos speed of sound or sonic temperature
 - abst absolute temperature
 - a1 analogue input 1
 - a2 analogue input 2
 - a3 analogue input 3
 - a4 analogue input 4
 - a5 analogue input 5
 - a6 analogue input 6
 - clino inclinometer x and y in 0.01° steps
 - none anemometer status and wind data only
- Analogue inputs are output in volts to 4 decimal places.
- If no selection of additional data is made then all the available data is converted.
- A reminder of the above commands can be obtained by typing `convert3 help`.

6. USING THE ANEMOMETER WITH A PC RUNNING YOUR SOFTWARE

6.1 Digital Serial Output Format

Data is sent in either binary or ASCII format as follows:

6.1.1 Binary Result Message Format

0xBA 0xBA StaA StaD Wc₁H Wc₁L Wc₂H Wc₂L Wc₃H Wc₃L CH CL TH TL A₁H A₁L
 ... A_nH A_nL cc

where:

0xBA 0xBA	-	Start of result message identifier. 2 bytes, hex value BA.
StaA	-	Status Address
StaD	-	Status Data
Wc ₁	-	Wind component 1
Wc ₂	-	Wind component 2
Wc ₃	-	Wind component 3
C	-	Speed of sound
T	-	Absolute temperature
A ₁	-	Analogue input 1
A _n	-	Analogue input n
Cc	-	checksum of all bytes. The checksum is an exclusive OR of all bytes excluding the 2 start bytes.

These fields are defined as follows:

Wind Component Fields

UVW format Wc₁ U axis velocity in 0.01ms⁻¹ units (Two's complement signed)
 Wc₂ V axis velocity in 0.01ms⁻¹ units (Two's complement signed)
 Wc₃ W axis velocity in 0.01ms⁻¹ units (Two's complement signed)

Polar format Wc₁ U V plane velocity direction in ° relative to N.
 Wc₂ U V plane velocity magnitude in 0.01ms⁻¹ units.
 Wc₃ W axis velocity in 0.01ms⁻¹ units (Two's complement signed)

Axis Speeds Wc₁ Ultrasonic axis 1 velocity in 0.01ms⁻¹ units (Two's complement signed)
 Wc₂ Ultrasonic axis 2 velocity in 0.01ms⁻¹ units (Two's complement signed)
 Wc₃ Ultrasonic axis 3 velocity in 0.01ms⁻¹ units (Two's complement signed)

Speed of Sound Field

Speed Of Sound	Speed of sound in 0.01ms^{-1} units (Unsigned)
Sonic Temperature	Sonic temperature in 0.01K (Unsigned) or 0.01°C (Two's complement signed)

Absolute Temperature Field

Absolute Temperature in 0.01K (Unsigned) or 0.01°C (Two's complement signed)

Analogue Input Fields

Analogue input value in twos complement:

0000	0.0000V
1FFF	+4.9994V
E000	-5.0000V

Checksum Field

Exclusive OR of all bytes excluding the two start bytes.

6.1.2 ASCII Result Message Format

<STX>StaA, StaD,Wc₁,Wc₂,Wc₃,C,T,A₁,...,A_n,<ETX>cc<TERM>

where:

<STX>	-	Start of string character (ASCII value 2)
StaA	-	Status Address
StaD	-	Status Data
Wc ₁	-	Wind component 1
Wc ₂	-	Wind component 2
Wc ₃	-	Wind component 3
C	-	Speed of sound
T	-	Absolute temperature
A ₁	-	Analogue input 1
A _n	-	Analogue input n.
<ETX>	-	End of string character (ASCII value 3)
cc	-	checksum of all characters between <STX> and <ETX>
<TERM>	-	<CR> or <CR><LF>, user selectable

These fields are defined as follows:

Wind Component Fields

UVW format	Wc ₁	U axis velocity in 0.01ms^{-1} units ($\pm\text{UU.UU}$)
	Wc ₂	V axis velocity in 0.01ms^{-1} units ($\pm\text{VV.VV}$)
	Wc ₃	W axis velocity in 0.01ms^{-1} units ($\pm\text{WW.WW}$)
Polar format	Wc ₁	U V plane velocity direction in $^{\circ}$ relative to N (DDD)
	Wc ₂	U V plane velocity magnitude in 0.01ms^{-1} units (MM.MM)
	Wc ₃	W axis velocity in 0.01ms^{-1} units. ($\pm\text{WW.WW}$)

Axis Speeds	Wc ₁	Ultrasonic axis 1 velocity in 0.01ms ⁻¹ units ($\pm A_1A_1.A_1A_1$)
	Wc ₂	Ultrasonic axis 2 velocity in 0.01ms ⁻¹ units ($\pm A_2A_2.A_2A_2$)
	Wc ₃	Ultrasonic axis 3 velocity in 0.01ms ⁻¹ units ($\pm A_3A_3.A_3A_3$)

Speed of Sound Field

Speed Of Sound	Speed of sound in 0.01ms ⁻¹ units (CCC.CC)
Sonic Temperature	Sonic temperature in 0.01K (KKK.KK) or 0.01°C ($\pm CC.CC$)

Absolute Temperature Field

Absolute Temperature in 0.01K or 0.01°C (TTT.TT) or 0.01°C ($\pm CC.CC$)

Analogue Input Fields

Analogue input value in volts ($\pm v.vvvv$)

Checksum Field

Exclusive OR of all characters between <STX> and <ETX> reported as ASCII hex.

6.1.3 Status Fields

There are a number of different status codes, which give the user information about various aspects of the anemometer. Each of these codes has an address field followed by a data field. The address field defines which particular aspect of the anemometer the following data field refers to.

The address fields are defined as follows:

StaA - Status Address

Address	Function
00	Error codes
01	Anemometer configuration
02	Data output configuration 1
03	Data output configuration 2
04	Error code history
05	Transducer gain levels
06	Anemometer Type
07	Inclinometer X axis MSB
08	Inclinometer X axis LSB
09	Inclinometer Y axis MSB
10	Inclinometer Y axis LSB

In normal operation the anemometer output cycles through the status codes 01 - 06 at each output sample. If the anemometer detects an error then the status code 00 is displayed instead of the next cyclic status code. When the error is cleared, the status codes will continue to cycle from where they were interrupted.

If the error is caused by a transducer pair failure then the error code is displayed until the failure is rectified.

If the error is caused by a memory or PRT failure, then after 16 consecutive failed readings, the error condition is reduced to the error code history status and the error cleared.

StaD - Status Data**Address 00 - Error codes**

Bit	Function
0	Transducer pair 1 failed.
1	Transducer pair 2 failed
2	Transducer pair 3 failed
3	Reserved
4	Non-volatile memory error
5	PRT failed
6	Reserved
7	Reserved

Address 01 - Anemometer configuration

Bit	Function
0	Reserved
1	PRT fitted
2	Reserved
3	Inclinometer fitted
4	0 U, V, W axis definition (U aligned with transducer axis 1 when viewed from above)
	1 U', V', W' axis definition (U' aligned with the spar)
5	Reserved
6	Reserved
7	Reserved

Address 02 - Data output configuration 1

Bits 1,0

00	Wind mode UVW
01	Wind mode axis
10	Polar 360 wrap
11	Polar 540 wrap

Bits 3,2

00	$\pm 10\text{ms}^{-1}$ Full Scale Deflection
01	$\pm 20\text{ms}^{-1}$ Full Scale Deflection
10	$\pm 30\text{ms}^{-1}$ Full Scale Deflection
11	$\pm 60\text{ms}^{-1}$ Full Scale Deflection

Bits 5,4

00	SOS report off
01	SOS report speed of sound
10	SOS report sonic temp. K
11	SOS report sonic temp. C

Bits 7,6

00	PRT temp. off
01	PRT temp. K
10	PRT temp. C
11	Reserved

Address 02 is repeated for 8 samples after a power on reset or exit from 'Interactive Mode' to allow the analogue output card or custom PC software to recognise the output configuration.

Address 03 - Data output configuration 2

Bits 2,1,0

000	No inputs enabled
001	1 input enabled
010	2 inputs enabled
011	3 inputs enabled
100	4 inputs enabled
101	5 inputs enabled
110	6 inputs enabled
111	Not used

Bit 3

0	Reserved
1	Reserved

Bits 5,4

00	Reserved
01	Reserved
10	Reserved
11	Reserved

Bits 7,6

00	Reserved
01	Reserved
10	Reserved
11	Reserved

Address 04 - Error code history

Bit	Function
0	Reserved
1	Reserved
2	Reserved
3	Reserved
4	Non-volatile memory error
5	PRT failed
6	Reserved
7	Reserved

The error history is cleared when the user enters interactive mode.

Address 05 - Transducer gain levels

Bits 1,0

- 00 Channel pair 1 nominal
- 01 Channel pair 1 @ 50%
- 10 Channel pair 1 @ 90%
- 11 Channel pair 1 @ 100%

Bits 3,2

- 00 Channel pair 2 nominal
- 01 Channel pair 2 @ 50%
- 10 Channel pair 2 @ 90%
- 11 Channel pair 2 @ 100%

Bits 5,4

- 00 Channel pair 3 nominal
- 01 Channel pair 3 @ 50%
- 10 Channel pair 3 @ 90%
- 11 Channel pair 3 @ 100%

Bits 7,6

Reserved

Address 06 - Anemometer type

Bits 2,1,0

- 000 Single axis
- 001 Omnidirectional or Asymmetric
- 010 Three Axis Horizontal
- 011 Reserved
- 100 Reserved
- 101 Reserved
- 110 Reserved
- 111 Reserved

Bits 7,6,5,4,3 Not used.

Address 07 - Inclinometer X axis MSB**Address 08 - Inclinometer X axis LSB****Address 09 - Inclinometer Y axis MSB****Address 10 - Inclinometer Y axis LSB**

The above data are output as 16 bit twos complement numbers. In ASCII output format two hex characters are output for each status address.

If an inclinometer is not fitted or faulty the above addresses are not output.

6.1.4 Software commands**Command Format**

All commands are entered as an ASCII string consisting of a mnemonic, representing the operation, and zero or more parameters separated by spaces and terminated by either <CR> or <CR><LF>. The case of the characters in the command is ignored.

Commands are only valid whilst in the interactive mode, with the exception of the “enter interactive mode” command and polled data request command.

ASCII Output String Termination

The ASCII output string terminator can be configured to be either <CR> or <CR><LF>. The expression <TERM> is used to indicate either one of these string terminators.

Character Echo

Character echo can be enabled or disabled. If enabled, received characters are only echoed while in interactive mode.

The Backspace Character

The anemometer will respond to the <BACKSPACE> character by deleting the previous character from its command buffer, and echo <BACKSPACE><SPACE><BACKSPACE>.

The Escape Character

The anemometer will respond to the <ESC> character by deleting all characters currently in its command buffer, and echo <TERM><TERM>.

Command Responses

Command responses are only issued when in interactive mode.

Configuration Commands

On receipt of a configuration command, the anemometer will respond with a validation message if the command was successfully actioned, or an appropriate error message if it was not. If a configuration command is entered with no data parameter, the current data value is returned.

Interrogation Commands

On receipt of an interrogation command, the anemometer responds with the requested information if the command was successfully completed, or an appropriate error message if it was not.

Invalid Combinations of Commands

It is possible through the setting of various parameters to request a configuration where the required output bit rate exceeds the configured baud rate.

If an issued configuration command requests a parameter change that would cause the above situation, an appropriate error message is generated.

COMMANDS

The command descriptions use a modified form of the BNF format:-

	Option, one option from a list separated by the vertical bar must be included
in	the command.
()	Parenthesis, used to make the possible combinations unambiguous.
[]	Option, the symbols within the square braces are optional.
n{ }m	Repeat, the symbols inside the braces can be repeated n to m times. If n is not included then 0 is implied, if m is not present then infinity is implied.
<>	Non literal symbol, this represents other non literal and literal symbols. A further definition is required to define this non literal symbol.

IM

Syntax: IM

Description: Switches from measurement mode to interactive mode.

EXIT

Syntax: EXIT

Description: Exits from interactive mode back to measurement mode.

AVERAGE

Syntax: AVERAGE 1...250

Description: Sets the number of samples used in the block average.

WINDREP

Syntax: WINDREP (UVW | POLAR) (CAL | UNCAL) | AXIS

Description: Sets the wind measurement reporting format.

Parameters: UVW Reports wind velocity in UVW format.

POLAR Reports wind velocity in polar + W format.

AXIS Reports wind as axis velocities.

CAL Wind results are calibrated.

UNCAL Wind results are uncalibrated.

SOSREP

Syntax: SOSREP OFF | SPEED | (SONICTEMP K | C)

Description: Sets the speed of sound reporting format.

Parameters: OFF SOS reporting is turned off.

SPEED SOS is reported as speed.

SONICTEMP SOS is reported as sonic temperature.

K Sonic temperature reporting in K.

C Sonic temperature reporting in °C.

ABSTEMP

Syntax: ABSTEMP OFF | (ON K | C)

Description: Enables and disables absolute temperature reporting from the PRT sensor.

Parameters: OFF PRT temperature reporting turned off.

ON PRT temperature reporting turned on.

K PRT temperature reporting in K.

C PRT temperature reporting in °C.

ANAIP

Syntax: ANAIP <ipno>{,< ipno> }6 (D | E)
<ipno> = 1 | 2 | 3 | 4 | 5 | 6

Description: Turns on or off the specified analogue inputs.

Parameters: ipno Analogue input channel number.

D Disable specified channels.

E Enable specified channels.

AOPFSD

Syntax: AOPFSD 10 | 20 | 30 | 60

Description: Specifies the analogue outputs full scale deflection. Used to configure the analogue output box only.

POLARWRAP

Syntax: POLARWRAP 360 | 540

Description: Specifies the analogue outputs polar reporting wrap angle. Used to configure the analogue output box only.

STRFMT

Syntax: STRFMT BINARY | ASCII (PAD | UNPAD)

Description: Sets the result message string format.

Parameters: BINARY Binary result message format.
ASCII ASCII result message format.
PAD ASCII fields padded to fixed size.
UNPAD ASCII fields unpadded.

ASCTERM

Syntax: ASCTERM CR | CRLF

Description: Sets ASCII output string terminator.

Parameters: CR ASCII output string terminator is <CR>.
CRLF ASCII output string terminator is <CR><LF>.

ECHO

Syntax: ECHO OFF | ON

Description: Turns on or off character echoing.

Parameters: OFF Turn off character echoing.
ON Turn on character echoing.

MSGMODE

Syntax: MSGMODE CONT | POLL

Description: Sets the message reporting mode.

Parameters: CONT Result messages are reported continuously.
POLL Result messages are requested by the user.

BAUD

Syntax: BAUD 2400 | 4800 | 9600 | 19200 | 38400 | 57600 | 115200

Description: Sets the serial interface baud rate. Selection must be confirmed with a letter B.

CTONE

Syntax: CTONE ON | OFF | DISABLE

Description: Enables an audible confidence tone

Parameters: ON Enables the confidence tone
OFF Disables the tone until the anemometer is next powered up.
DISABLE Disables the tone until the function is enabled using CTONE ON.

?

Syntax: ?

Description: Request the current results message when in polled mode.

HELP

Syntax: HELP

Description: Reports a brief description of all the available commands.

Syntax: HELP command

Description: Reports a description of the command requested.

SN

Syntax: SN

Description: Reports the anemometer's serial number.

VER

Syntax: VER

Description: Reports the anemometer's software version.

CONFIG

Syntax: CONFIG

Description: Reports the anemometer's configuration.

INCL

Syntax: INCL

Description: Reports the inclination of the anemometer from the vertical axis.
The format is $\pm XX.XX$, $\pm YY.YY$.

VERIFY

Syntax: VERIFY E/D

Description: Enables or disables messages to verify that commands have been carried out. The verification message is the command name prefixed by "V". e.g. "VAVERAGE" for and "AVERAGE" command.

Parameters: E enables verification messages.
D disables verification messages.

ALIGNUVW

Syntax: ALIGNUVW AXIS | SPAR

Description: Selects UVW alignment from two alternative definitions

Parameters: AXIS Aligns the U axis to transducer axis 1 when viewed from above.
SPAR Aligns the U axis with the main spar.

7. USING THE ANALOGUE INPUTS OF THE ANEMOMETER

Six differential analogue inputs are available of 14-bit resolution. A specification for these is given in Section 11.6. This feature allows the user to power extra equipment local to the anemometer and to take analogue data from that equipment. The anemometer digitises the analogue data and appends it to the digital data string.

A sensor supply voltage is available at each connector. The voltage at this connector is the supply voltage at the anemometer minus 1.5 volts. The sensor supply voltage is internally regulated to 21 ± 2 volts for anemometer supply voltages above 22 volts.

For sensors with a common supply and signal ground, this ground should be connected to Sensor Supply -. In this situation Analogue Input - should be connected to Sensor Supply - and Analogue Ground left floating.

The **total** current drawn from the sensor supply by all the external sensors must not exceed 70mA.

Sensor connector pin out:

- | | |
|---|-----------------------------|
| 1 | Sensor power - |
| 2 | Analogue input 1+ / 3+ / 5+ |
| 3 | Analogue ground |
| 4 | Analogue input 1- / 3- / 5- |
| 5 | Analogue input 2+ / 4+ / 6+ |
| 6 | Analogue input 2- / 4- / 6- |
| 7 | Sensor power + |
| 8 | Chassis/screen |

8. USING THE PRT INPUT

The anemometer is set up to operate with any 4 wire PRT conforming to IEC 751 or DIN 43760. Compatibility with other standards may be available on request.

PRT connector pin out:

- 1 Sensor power +
- 2 Analogue input 6 +
- 3 Analogue input 6 -
- 4 Analogue ground
- 5 PRT excitation +
- 6 PRT excitation -
- 7 PRT sense +
- 8 PRT sense -
- 9 Sensor power -
- 10 Chassis/screen

PRT connection diagram:

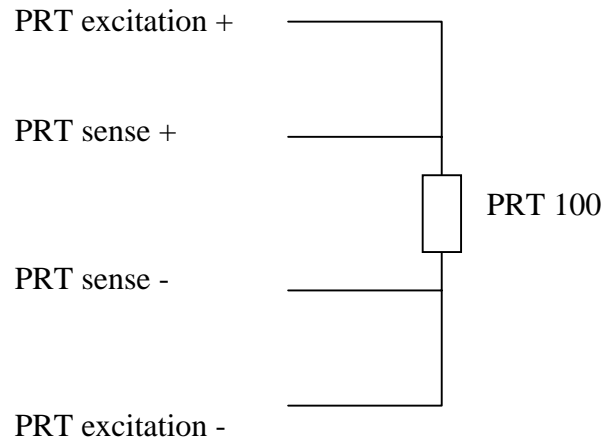

For correct operation the PRT connections must be isolated from the rest of the system.

9. USING THE ANALOGUE OUTPUTS

9.1 Introduction

Analogue outputs can be provided by an additional analogue output card mounted inside the power supply and communications unit (PCI). PCIs with this card fitted have a model number 1189PCA. PCIs without analogue outputs have a model number 1189PC.

The analogue output card decodes the serial message from the anemometer and generates the appropriate analogue outputs. Seven analogue outputs are provided of 14 bit resolution. The pin assignment and electrical specification for these is given in Section 12.

9.2 Analogue outputs

Channels 1,2 and 3 - Wind velocity

These channels represent the wind velocity. The variables represented by each channel depend on the anemometer's operating mode, and are defined in the following table:

Mode	Output Channel		
	1	2	3
UVW	U	V	W
Polar format	Dir.	Mag.	W
Axis velocities	Axis 1	Axis 2	Axis 3

For U, V and W magnitude, and axis velocities, $\pm 2.5V$ represents ± 10 , ± 20 , ± 30 or $\pm 60m/s$ as selected when configuring the anemometer. For direction in polar format the $\pm 2.5V$ output range represents either 360° or 540° . This option is also set up when configuring the anemometer, either using the supplied RCOM software or using the anemometer's interactive mode commands.

The direction representation is:

	Output voltage (V)				
	-2.5	-0.833	0	+0.833	+2.5
360°	-180°		0°		+180°
540°	0°	180°		360°	+540°

The 540° mode avoids the output oscillating between $-2.5V$ and $+2.5V$ in response to a direction varying around 180° .

Channel 4 - Speed of Sound or Sonic Temperature

The variable represented by this analogue output also depends on the configuration of the anemometer's speed of sound or sonic temperature. The representations for each available mode are:

	Output voltage (V)			
	-2.5	-1.667	0	+2.5
Speed of Sound	300	311.667	335	370
Sonic temperature (Kelvin)		233.15	273.15	333.15
Sonic temperature (Celsius)		-40	0	+60

Channel 5 - Absolute Temperature

The voltage output at a given temperature is independent of the anemometer's temperature output configuration. The following table shows the mapping between voltage and temperature:

	Output voltage (V)		
	-1.667	0	+2.5
Celsius	-40	0	+60
Kelvin	233.15	273.15	333.15

Channel 6 - Reserved for future expansion

This analogue output is not currently used.

Channel 7 and 8 - Analogue Inputs

Channels 7 and 8 echo the voltage on the lowest two analogue inputs that are enabled i.e. the first two in the serial data message from the anemometer. The analogue inputs at the anemometer are in the range $\pm 5V$. The analogue outputs have a range of $\pm 2.5V$. The voltage output is half the analogue input value. For example an analogue input of $+5V$ is echoed at $+2.5V$.

9.3 Analogue Sync. Output

A logic 1 on the Analogue Sync output indicates that the analogue outputs have settled. A logic 0 is generated during the period when the analogue outputs are being updated (approximately 2ms duration). The pin assignment and electrical specification of the Analogue Sync. output are contained in Section 12.

9.4 Status Output

A logic 1 on the status output indicates that the analogue outputs are valid (i.e. the full set of configuration data have been received from the anemometer and there are no data errors for the current output data). The pin assignment and electrical specification of the status output are contained in Section 12.

9.5 Test Modes

The analogue output system includes two self-test modes. They are activated by the pulling low the relevant pin on the main 25-way connector, and remain active until the pin is pulled high or allowed to go open circuit. The pin assignment and electrical specification are contained in Section 12.

Pulling Test Pin 1 low causes all eight analogue outputs to simultaneously cycle through the following sequence of voltages:

-2.50v, -1.25v, 0.00v, 1.25v, 2.50v

The outputs remain at each voltage for four seconds so that the sequence repeats every twenty seconds. Pulling Test Pin 2 low causes the same sequence of voltages to be output on each channel in turn, while the unused channels are held at 0.00v. i.e. the sequence is first output on channel 1, then channel 2, then 3 etc. For this test the complete sequence lasts 160 seconds.

10. DRAWINGS

1086-M-043 Anemometer Cable (Voltage Out)

NOTE:
EXISTING SHIELD PROVIDED WITH CONNECTOR IS DISCARDED.

NOTE:
TO ALL OTHER SOLDER CONNECTIONS.

NOTES:

1. STRIP BACK OUTER SHEATH AT HIROSE END BY 45mm AND STRIP INDIVIDUAL WIRES 3mm.
2. STRIP BACK OUTER SHEATH AT 'D' CONNECTOR END BY 25mm AND STRIP INDIVIDUAL WIRES 3mm.
3. TWIST INDIVIDUAL DRAIN WIRES TOGETHER AND SLEEVE OVERALL WITH A 45mm LENGTH OF HEATSHRINK SLEEVE (026-01017) AT THE HIROSE CONNECTOR END AND A 25mm LENGTH AT THE 'D' CONNECTOR END.
4. FIT HELLERMAN SLEEVES 1.5 x 7mm (026-02463) TO DRAIN WIRE SOLDER CONNECTIONS AND HELLERMAN SLEEVES 1.2 x 7mm (026-02462).
5. DISCARD SHIELD SUPPLIED WITH HIROSE CONNECTOR (020-02673) BUT RETAIN 'O' RING AND GRUBSCREW FOR USE WITH EXTENDED BACKSHELL.
6. DISCARD SCREEN CONNECTION SUPPLIED WITH 'D' CONNECTOR.
7. ENSURE OUTER CABLE SHEATH EXTENDS INTO THE EXTENDED BACKSHELL AND IS PROPERLY SECURED BY THE CORD CLAMP.

PAIR 1 SUPPLY V+ 6 YELLOW 9 CHASSIS 9 YELLOW
 SUPPLY V- 14 BLACK 10 BLACK

PAIR 2 RS485 TX+ 2 WHITE 11 WHITE
 RS485 TX- 3 BLACK 12 BLACK

PAIR 3 RS485 RX+ 4 BROWN 13 BROWN
 RS485 RX- 5 BLACK 14 BLACK

PAIR 4 DIGITAL OV 13 RED 15 RED
 ANA OV 15 BLACK 16 BLACK

PAIR 5 ANA O/P V₁ 18 GREEN 17 GREEN
 ANA O/P V₂ 10 BLACK 18 BLACK
 ANA O/P V₃ 17 BLUE 19 BLUE
 ANA O/P V₄ 1 BLACK 20 BLACK

PAIR 6 ANA O/P I₁ 8 X
 ANA O/P I₂ 7 X
 ANA I/P 1 20 X
 ANA I/P 2 16 X
 ANA I/P 3 19 X
 NOT USED 11 X
 NOT USED 12 X

NOT CONNECTED

DRAIN WIRES

1 SCREEN
 5 SUPPLY V+
 11 SUPPLY V-
 2 RS485 RX+
 9 RS485 RX-
 3 RS485 TX+
 10 RS485 TX-
 4 SIGNAL GND
 13 ANA GND
 6 ANA O/P 1
 8 ANA O/P 2
 15 ANA O/P 3
 12 ANA O/P 4
 7 NOT USED
 14 NOT USED

END VIEW OF CABLE AT HIROSE CONNECTOR END SHOWING CORRECT WIRE COLOUR ORIENTATION

SCALE: UNSCALED
GENERAL TOLERANCE: N/A
FINISH: N/A
USED ON: Third angle
MATERIAL: N/A

DATE: 23/5/98
APPROVED:
CHANGE NOTE NO.: 1562
2028

DATE: 22/5/98
20/5/99

DESCRIPTION:
5 CABLE DETAILS & NOTES ADDED
6 NOTE 6. ADDED
7 CABLE WAS 026-01630. COLOUR CODES CHANGED TO SUIT. HEATSHRINK SVWG DELETED. EXTENDED BACKSHELL ADDED.

TITLE: ANEMOMETER CABLE (VOLTAGE OUT) A3
BRAND: N W-W
DATE: 13-01-95
DWG NO.: 1086-M-043

GILL ELECTRONIC RESEARCH & DEVELOPMENT
 LYINGTON, ENGLAND. ©

1189-K-022 Indoor PCI Unit Dimensions

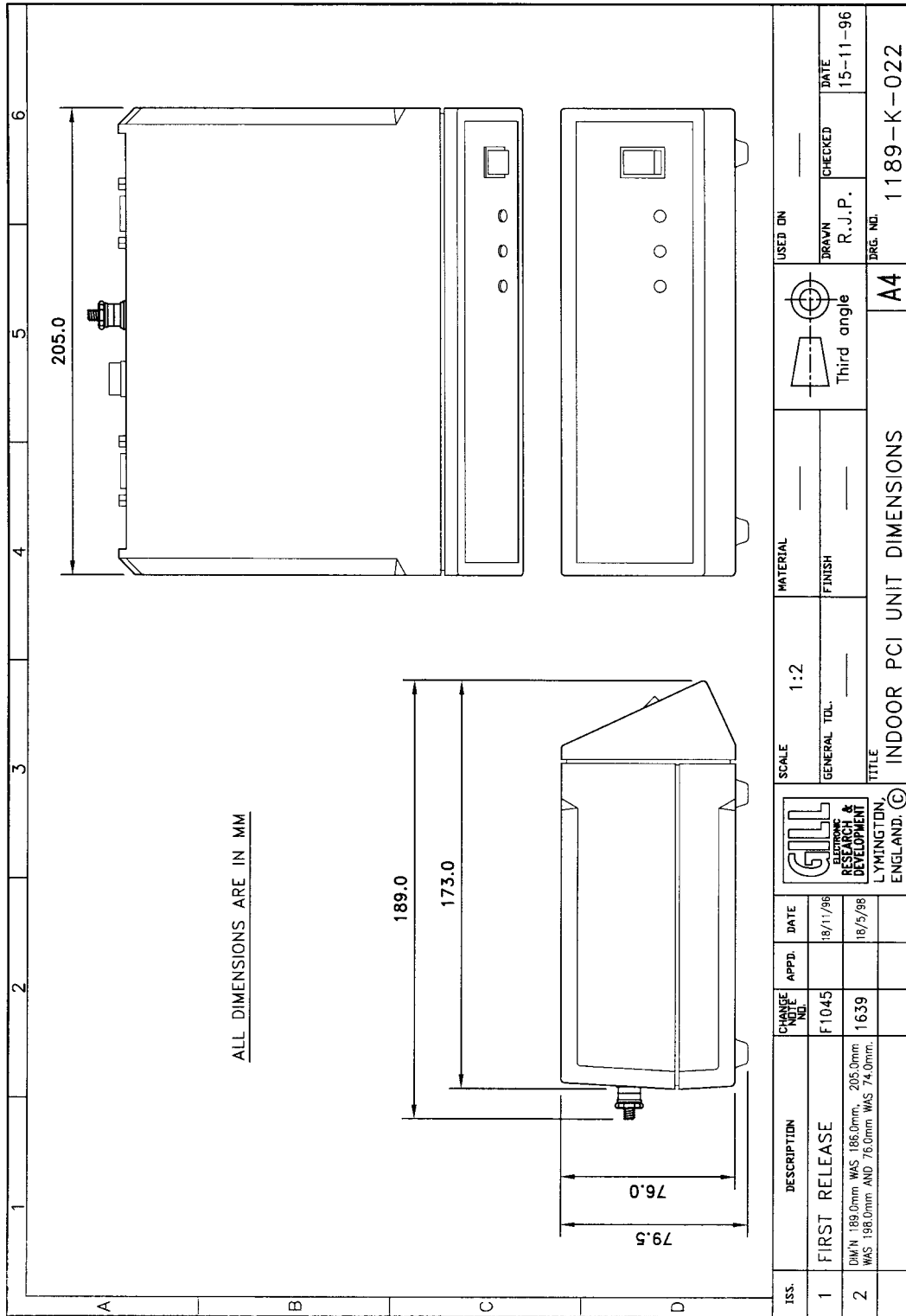

1199-K-066 3 Axis Horizontal Anemometer U,V &W Axis Definitions

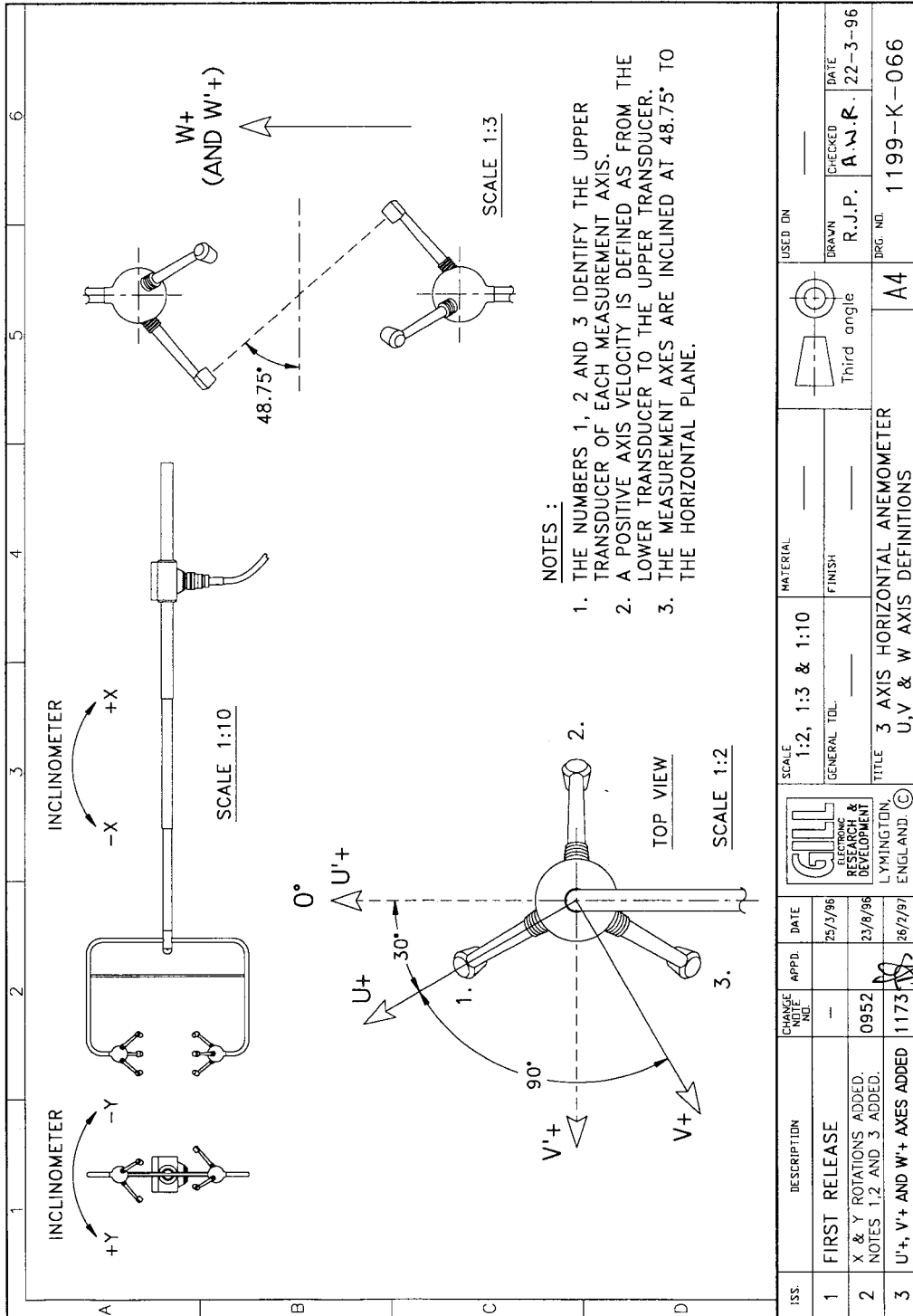

ISS	DESCRIPTION	CHANGE NOTE NO.	APPD.	DATE	SCALE	MATERIAL	USED IN
1	FIRST RELEASE	--		25/5/96	1:2, 1:3 & 1:10	FINISH	BRAWN R.J.P.
2	X & Y ROTATIONS ADDED. NOTES 1,2 AND 3 ADDED.	0952		23/8/98	GENERAL TOL.		CHECKED A.W.R.
3	U+, V+ AND W+ AXES ADDED	1173		26/2/97	TITLE 3 AXIS HORIZONTAL ANEMOMETER U,V & W AXIS DEFINITIONS		DATE 22-3-96 DRG. NO. 1199-K-066

1199-K-089 3 Axis Horizontal Anemometer Head + Electronics Mounting Details

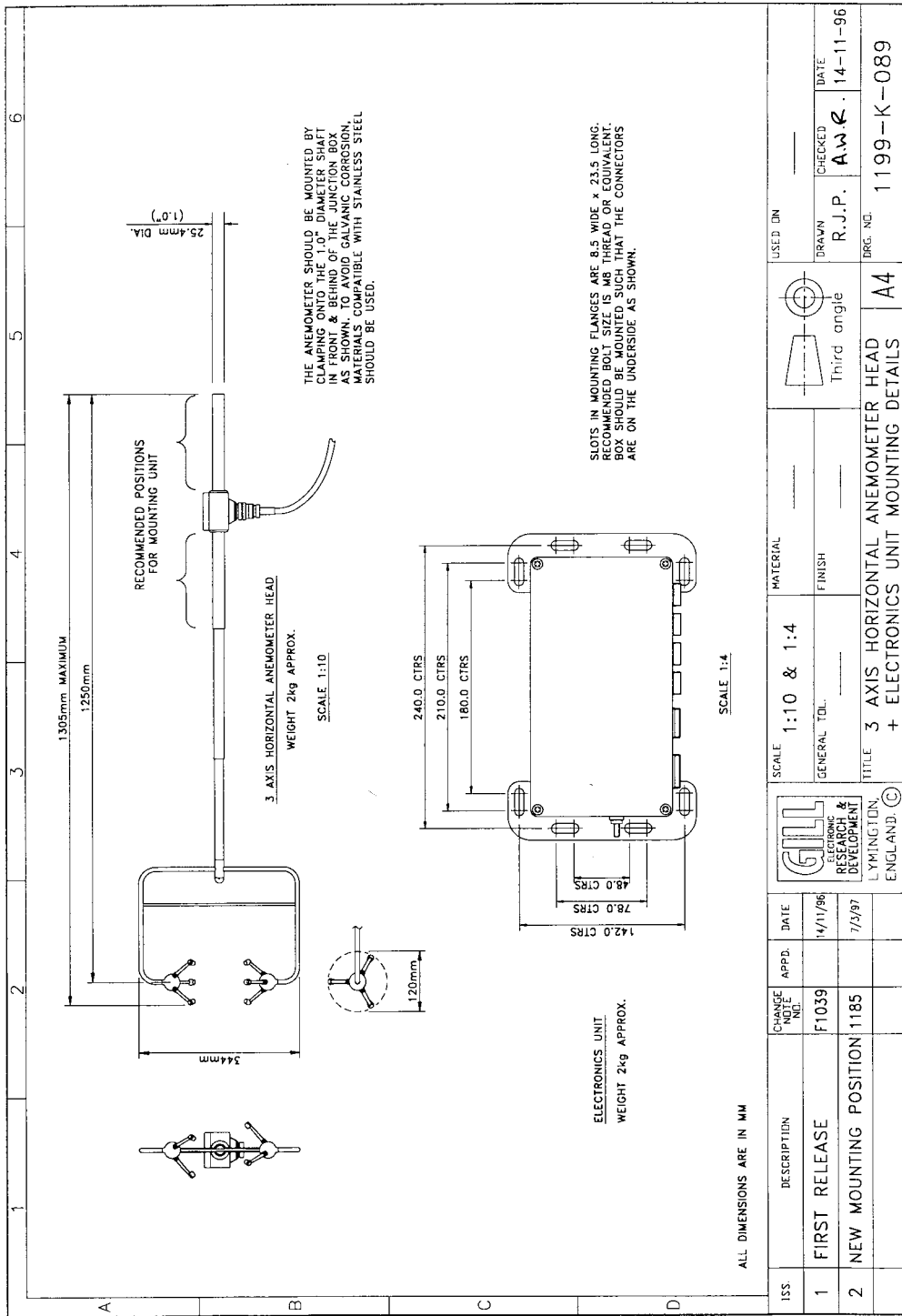

ISS.	DESCRIPTION	CHANGE NOTE NO.	APPD.	DATE	USED IN
1	FIRST RELEASE	F1039		14/11/96	DRAWN R.J.P. CHECKED A.W.R. DATE 14-11-96
2	NEW MOUNTING POSITION	1185		7/5/97	DRG. NO. 1199-K-089

MATERIAL	FINISH	Third angle	A4
SCALE 1:10 & 1:4	GENERAL TOL.	TITLE 3 AXIS HORIZONTAL ANEMOMETER HEAD + ELECTRONICS UNIT MOUNTING DETAILS	
GILL ELECTRONIC RESEARCH & DEVELOPMENT, LYMINGTON, ENGLAND. ©			

1210-K-068 R3 & HS Research Anemometer Measurement Sequence

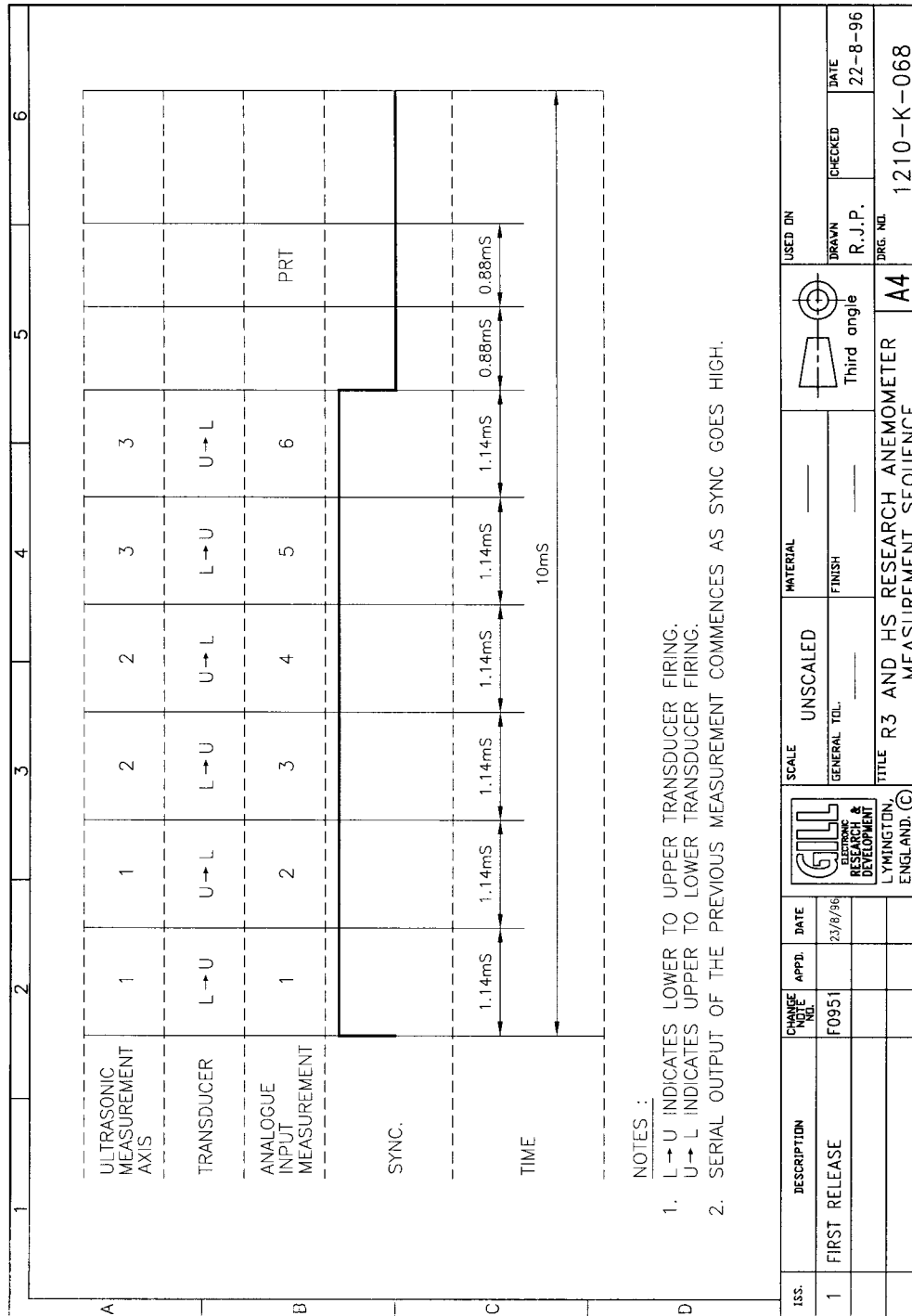

- NOTES :
1. L → U INDICATES LOWER TO UPPER TRANSDUCER FIRING.
U → L INDICATES UPPER TO LOWER TRANSDUCER FIRING.
 2. SERIAL OUTPUT OF THE PREVIOUS MEASUREMENT COMMENCES AS SYNC GOES HIGH.

Assembly of Amphenol C91A Screw Lock 4 Way Socket

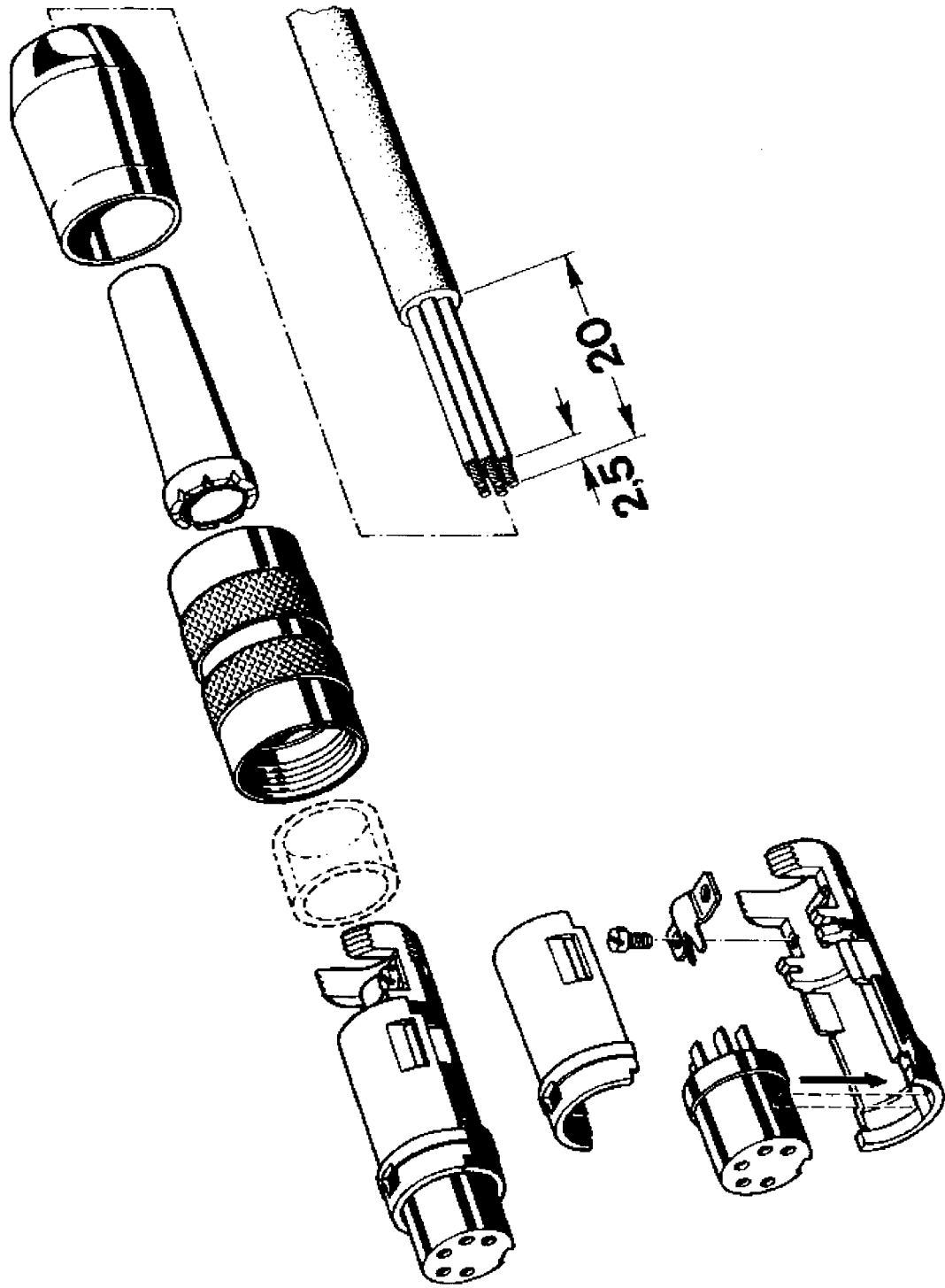

Assembly of Amphenol C91A Screw Lock 4 Way Socket

11. TECHNICAL SPECIFICATION

11.1 Wind Measurement

Measurement Rate:	100s ⁻¹ (Full 3 axis measurement)
Data Output Rates:	From 0.4 to 100s ⁻¹
Wind Speed Range:	0 to 45ms ⁻¹
Wind Speed Accuracy:	<1%rms
Wind Speed Resolution:	0.01ms ⁻¹
Wind Speed Offset:	<±0.01ms ⁻¹
Directional Accuracy:	<±1°RMS
Directional Resolution:	1°

11.2 Speed of Sound Measurement

Measurement Rate:	100s ⁻¹ (Synchronous to wind measurement)
SOS Range:	300-370ms ⁻¹
SOS Accuracy:	<±0.5% (For wind speeds <30ms ⁻¹)
SOS Resolution:	0.01ms ⁻¹

Accuracy specifications apply for wind speeds <32m/s and for wind incidence within ±50° of horizontal.

11.3 Environmental

Operating Temperature:	-40°C to +60°C
Storage Temperature:	-50°C to +75°C
Relative Humidity:	5% to 100%
Precipitation:	up to 300mm/hr
Altitude:	0 to 3000m
Moisture ingress:	IP65
Suitable for marine environment	
EMC Emissions:	BS EN 50082-1:1992
EMC Immunity:	BS EN 50081-1:1992
Input/Output Protection:	>0.8J

11.4 Supply Input

Supply Voltage:	9 to 30VDC
Supply Current:	<300mA for 12Vdc input <150mA for 24Vdc input

11.5 Serial Interface

Electrical Interface:	Full Duplex RS422
Baud Rates:	2400, 4800, 9600, 19200, 38400, 57600, 115200
Format:	8 data, 1 stop bit, No parity

11.6 Analogue Inputs

Sampling Rate:	100s ⁻¹ Synchronous to wind measurement.
Diff. Input Voltage Range:	-5.000V to +5.000V
Accuracy:	>0.05% of full scale
Resolution:	14 bits
Common Mode Input Range:	>±8V
Input Impedance:	>1M Ohm (Differential) >1M Ohm (Common Mode)

11.7 PRT

Resolution:	0.01°C
Measurement Accuracy:	<±0.1°C (0°C to +50°C) <±0.15°C (-40°C to +60°C)

11.8 Anemometer Sync Output

RS422 synchronous to wind measurement.

11.9 Inclinometer

Range:	monotonic over ±30° of tilt
Resolution:	0.01°
Accuracy:	±0.3° for tilt angles between ±10°
Null Repeatability:	±0.15°
Temperature Coefficient-Null:	0.02° per °C
Temperature Coefficient-Scale Factor:	0.2% per °C

11.10 Anemometer Power and Data Connector Hirose 20 way socket

Connector pin	Designation
1	Reserved
2	RS422TXB (Data from anemometer)
3	RS422TXA (Data from anemometer)
4	RS422RXB (Data to anemometer)
5	RS422RXA (Data to anemometer)
6	Supply V+
7	Reserved
8	Reserved
9	Chassis
10	Anemometer Sync-
11	Not used
12	Not used
13	Digital 0V, signal ground
14	Supply V-
15	Reserved
16	Reserved
17	Reserved
18	Anemometer Sync +
19	Reserved
20	Reserved

12. POWER AND COMMUNICATIONS INTERFACE

12.1 Desk Top PCI

This unit is for use with a single research anemometer and performs the following functions:

- DC supply for the anemometer for mains or dc input.
- Conversion of the RS422 anemometer serial data to RS232 for connection to a PC.
- Transient protection for all anemometer connections.
- Optional analogue output card.
- Provision of an RS422 interface for transmission of serial data to a PC at higher baud rates or over long cables. RS232 is not recommended for baud rates above 19200 baud or for cable lengths greater than 15 metres.
- This is a desktop unit and not suitable for outdoor use.

12.2 Connector Pin Assignments

Anemometer Connector 15 way D type socket

Pin	Designation
1	Screen
2	RS422RXB (Data from anemometer)
3	RS422TXB (Data to anemometer)
4	Digital 0V, signal ground
5	Supply V+
6	Sync +
7	Not used
8	Sync -
9	RS422RXA (Data from anemometer)
10	RS422TXA (Data to anemometer)
11	Supply V-
12	Not used
13	Not used
14	Not used
15	Not used

RS232 connector 9 way D type socket

Pin	Designation
1	DCD
2	RXD (data from anemometer to PC)
3	TXD (data from PC to anemometer)
4	DTR
5	Signal Ground
6	DSR
7	RTS
8	CTS

RS422 connector 9 way D type socket

Pin	Designation
1	Not used
2	Not used
3	Not used
4	RS422 RXA(data from PC to PCI)
5	Signal GND
6	RS422 TXA(data from PCI to PC)
7	RS422 TXB(data from PCI to PC)
8	RS422 RXB(data from PC to PCI)
9	Earth (Screen)

D.C. Supply Amphenol C91A Screw Lock 4 Way Socket

Pin	Designation
1	PCI V+
2	PCI V-
3	Anemometer V-
4	Anemometer V+

View of PCI Plug

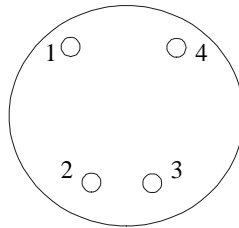

Auxiliary Output 9 way D type plug

Pin	Designation
6	Anemometer Sync +
7	Anemometer Sync -

Recommended Line Termination

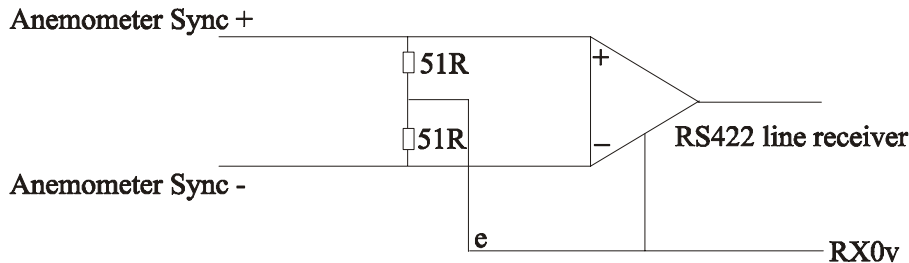

Note: The above termination is for when the receive circuit is floating relative to the anemometer. If the receive circuit is referred to Anemometer Signal Ground or Anemometer Supply - then the earth connection marked 'e' should be omitted.

Analogue Output Connector

Pin	Designation
1	Analogue ground 1
2	Analogue ground 2
3	Analogue ground 3
4	Analogue ground 4
5	Analogue ground 5
6	Analogue ground 6
7	Analogue ground 7
8	Analogue ground 8
9	Test pin 1
10	Signal ground
11	Earth
12	Signal ground
13	Signal ground

25 way D type plug

Pin	Designation
14	Analogue output 1
15	Analogue output 2
16	Analogue output 3
17	Analogue output 4
18	Analogue output 5
19	Analogue output 6
20	Analogue output 7
21	Analogue output 8
22	Test pin 2
23	Earth
24	Status output
25	Sync output

12.3 PCI Specification**Electrical power requirements**

- (a) 100Vac - 120Vac, 10VA for the 115V switch position
- (b) 200Vac - 250Vac, 10VA for the 230V switch position
- (c) 9 - 30Vdc, 400mA max (anemometer)
- 8 - 15Vdc, 50mA max (PCI)
- 8 - 15Vdc, 90mA max (PCI with analogue outputs)

Environmental

The desk top PCI is not sealed and is intended for use in a protected environment.

Analogue Outputs

The analogue outputs have the following specification:

Full scale range:	-2.5v to +2.5v
Accuracy:	0.25% of full scale (9 bits)
Resolution:	14 bits over $\pm 3.0v$
Settling time:	2ms to 0.25% accuracy (note that the minimum time between samples is 10ms)
Output resistance:	<0.5W at frequencies below 100Hz, short circuit proof
Load resistance:	Greater than 10kW
Load capacitance:	Between 0 and 1000pF (e.g. up to 10m of coaxial cable)

Analogue Sync and Status Outputs

Both Sync and status outputs conform to the following electrical specification:

Output Voltages:	high +3V to +5V
(referred to signal ground)	low <1V
Output resistance:	<100W, short circuit proof
Load resistance:	Greater than 10kW
Load capacitance:	Between 0 and 1000pF (e.g. 10m of coax)

Test 1, Test 2 Inputs

Logic high (inactive)

+3V to +5V or open circuit

Logic low (active)

<1V

The above voltages are referenced to signal ground.

APPENDIX A

SUMMARY OF ABBREVIATIONS USED IN THIS MANUAL

ASCII	American Standard Code for Information Interchange
PCI	Power & Communications Interface
EU	Electronics Unit
PRT	Platinum Resistance Thermometer
RS232	Communications standard
RS422	Communications standard
SoS	Speed of Sound
RCOM	Gill Instruments Ltd. PC communications software

PACKING LIST

Horizontally Symmetrical Research anemometer, comprising:

- Head
- Electronics Unit
- 1.5m interconnecting cable

- PCI
- Case
- RCOM software
- This manual

OPTIONAL EXTRAS

- Connectors
- PCI to EU cable. Available in a range of lengths
- Custom software on application

APPENDIX B

Principle of Operation

The basic time-of-flight operating principle is physically fundamental and provides vector measurement of air velocity dependent mainly on the dimensions and geometry of the transducer array. A pair of transducers act alternately as transmitters and receivers, sending pulses of high frequency ultrasound between themselves. The times of flight in each direction, say t_1 and t_2 , are measured. If c is the speed of sound, L the distance between the transducers and there is an air flow v along the line of the transducers, the following relationships are readily derived:-

$$t_1 = L/(c+v) \quad ; \quad t_2 = L/(c-v)$$

By inverting and subtracting, v is solved explicitly:-

$$v = 0.5L(1/t_1 - 1/t_2)$$

This wind vector derivation is not affected by c or any other parameters such as temperature or contaminant content.

Conversely, c is obtained by inverting and adding:-

$$c = 0.5L(1/t_1 + 1/t_2)$$

v represents the vector component of air flow resolved along the line of the pair of transducers. By arranging three pairs of transducers in different orientations, the direction and magnitude of the incident air flow may be unambiguously derived. The transducer pairs do not have to conform to cartesian axes. For optimum undisturbed airflow a non orthogonal arrangement is employed.

The main functions of the electronics are operation of the ultrasonics, processing of raw measurement data, and high level data analysis and data transmission.

The velocities along each transducer axis are calculated as above.

If the anemometer is operating in a UVW mode a transformation is then carried out to calculate the velocities in the U, V, W format. This transformation is given below.

If operating in a calibrated mode a correction operation is then applied to calibrate out the affects of the transducers and head framework. The UVW processed data are then output on the serial output.

Vector Transformation

a_1 = axis 1 velocity

a_2 = axis 2 velocity

a_3 = axis 3 velocity

Standard vector mathematics leads to the following equations:-

$$U \text{ velocity} = (2a_1 - a_2 - a_3)/1.9779$$

$$V \text{ velocity} = (a_3 - a_2)/1.1420$$

$$W \text{ velocity} = (a_1 + a_2 + a_3)/2.2555$$

APPENDIX C

Sonic Temperature Measurement

Sonic temperature measurement

Document No. 12100009/C

Page 1 of 7

GILL R and D	SONIC TEMPERATURE MEASUREMENT ON GILL INSTRUMENTS R3, R3A AND HS ANEMOMETERS		Iss : C Date:11-9-96 Doc :12100009
C/Note: None	Title	Signature	Date
Reviewed By:	Team Manager	A.W. Raby	11 th Sept 1996
Approved By:			

(1) INTRODUCTION

In the past most sonic anemometers have used the times of flight on only one axis to calculate the sonic temperature. However Gill Instruments R3, R3A and HS anemometers use times of flight from all three axes to derive the sonic temperature. This has the following advantages:

1. Noise reduction due to averaging over three axes.
2. Reduction of errors caused by wind shadowing on a single measurement axis in specific wind directions.
3. Cancellation of measurement errors caused by the anemometer head bending. However stiff the head assembly is made some bending is inevitable in strong winds.
4. Better correlation between the velocity and temperature measurements, since both are derived from the same set of six transit times.
5. Simpler implementation, because crosswind correction can be carried out without complicated vector algebra or trigonometric functions.

(2) SONIC TEMPERATURE MEASUREMENT FOR A SINGLE AXIS

Reference 1 gives a clear description of the principle of sonic thermometry. Its main results relevant to this technical note are reviewed in sections 2 and 3 before widening the discussion to cover the measurement of sonic temperature using data from three measurement axes. Assuming that there is no crosswind the speed of sound is evaluated over a single measurement axis, e.g. axis 1, according to the following formula:

$$c_1 = \frac{1}{2} \left(\frac{d_1}{t_{1,up}} + \frac{d_1}{t_{1,down}} \right) \quad 1$$

Sonic temperature measurement

Document No. 12100009/C

Page 2 of 7

The corresponding sonic temperature, which closely approximates the virtual temperature of the air, is calculated according to the following equation:

$$T_{s1} = \frac{c_1^2}{403} \quad 2$$

Finally, the true temperature may be calculated according to equation (3) if concurrent humidity measurements are available.

However the sonic anemometers manufactured by Gill Instruments do not carry out this calculation because they do not incorporate humidity sensors.

$$T = \frac{T_{s1}}{1 + 0.32 e/p} \quad 3$$

Where: c_1 = speed of sound, evaluated over axis 1
 d_1 = distance between transducers on axis 1
 $t_{1,up}$ = time of flight on axis 1 in one direction
 $t_{1,down}$ = time of flight on axis 1 in other direction
 T_{s1} = sonic temperature evaluated over axis 1.
 T = true temperature (Kelvin)
 e = vapour pressure of water in air
 p = absolute pressure

Equation (1) assumed that there was no crosswind (i.e. no component of wind normal to the measurement axis). However this is not a valid assumption and can result in significant error unless corrected. The method of crosswind correction is described in the next section.

(3) CROSSWIND CORRECTION OF SONIC TEMPERATURE MEASURED ON A SINGLE AXIS

The component of wind velocity normal to measurement axis 1 causes an error in the sonic temperature measurement. In the presence of such a crosswind the formulae in section 2 give sonic temperature and speed of sound values lower than the true values. The reason for this is that sound arriving at the receiving transducer left the transmitting transducer heading slightly up wind and was blown back on course, thus travelling further than the straight-line path length between the two transducers. Reference 1 derives the correction for crosswind errors. Applying the correction to the equations of section 2 gives:

$$T_{s1} \text{ (corrected)} = \frac{c_1^2}{403} + \frac{v_{n1}^2}{403} \quad 4$$

Where: v_{n1} = the component of wind velocity normal to axis 1

Sonic temperature measurement

Document No. 12100009/C

Page 3 of 7

In other words the sonic temperature may initially be calculated according to the simplified equations (1) and (2), and subsequently corrected by adding a term derived from the crosswind component.

(4) SONIC TEMPERATURE MEASUREMENTS AVERAGED OVER THREE MEASUREMENT AXES

The sonic temperature may also be derived from the other two measurement axes, giving the following formulae:

$$T_{s2} \text{ (corrected)} = \frac{c_2^2}{403} + \frac{v_{n2}^2}{403} \quad 5$$

$$T_{s3} \text{ (corrected)} = \frac{c_3^2}{403} + \frac{v_{n3}^2}{403} \quad 6$$

Where: c_2 = speed of sound evaluated over axis 2
 T_{s2} = sonic temperature evaluated over axis 2
 v_{n2} = the component of wind velocity normal to axis 2
 c_3 = speed of sound evaluated over axis 3
 T_{s3} = sonic temperature evaluated over axis 3
 v_{n3} = the component of wind velocity normal to axis 3

The axis speeds of sound c_2 and c_3 are calculated by substituting the times of flight and path length for the relevant axis into equation (1). Calculating the mean of the three sonic temperature measurements results in the benefits identified in section 1 of this technical note. The mean sonic temperature is:

$$T_s \text{ (corrected)} = \frac{1}{3} \left(\frac{c_1^2}{403} + \frac{c_2^2}{403} + \frac{c_3^2}{403} \right) + \frac{1}{3} \left(\frac{v_{n1}^2}{403} + \frac{v_{n2}^2}{403} + \frac{v_{n3}^2}{403} \right) \quad 7$$

The first term in this equation is the mean of the sonic temperatures for the three measurement axes, ignoring the effects of crosswind. This is subsequently corrected by adding the second term, which is the crosswind correction factor:

$$T_{\text{cross}} = \frac{1}{3} \left(\frac{v_{n1}^2}{403} + \frac{v_{n2}^2}{403} + \frac{v_{n3}^2}{403} \right) \quad 8$$

Where: T_s = the mean sonic temperature for all three axes
 T_{cross} = crosswind correction for sonic temperature

Sonic temperature measurement

Document No. 12100009/C

Page 4 of 7

Calculation of the uncorrected mean sonic temperature from the times of flight for the three axes is straightforward. The crosswind correction term looks more complicated to calculate because the wind velocity vector normal to each measurement axis has to be calculated in real time at the anemometer's sampling rate. However further analysis shows that the crosswind correction term can be simplified.

(5) CROSSWIND CORRECTION OF AVERAGED SONIC TEMPERATURE

The anemometer calculates the wind velocity in terms of rectangular cartesian coordinates. The alignment of the u , v and w wind vectors relative to the transducer axes is shown on the following diagram:

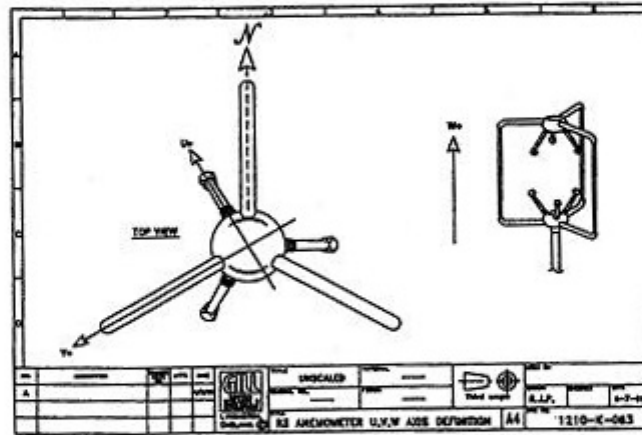

In this document vector quantities are represented by bold type. The wind velocity represented in vector notation is:

$$\text{velocity} = \begin{bmatrix} u \\ v \\ w \end{bmatrix} \quad 9$$

However the solution for the crosswind correction factor for data averaged over three axes is easier if the u , v and w components of velocity are expressed in polar notation:

$$\text{velocity} = \begin{bmatrix} |\text{velocity}| \cos\theta_w \cos\phi_w \\ -|\text{velocity}| \sin\theta_w \cos\phi_w \\ |\text{velocity}| \sin\phi_w \end{bmatrix} \quad 10$$

Sonic temperature measurement

Document No. 12100009/C

Page 5 of 7

Where:

θ_w = Azimuth angle of wind, measured clockwise from u axis
 ϕ_w = Elevation angle of wind, measured up from horizontal
 $|\text{velocity}|$ = magnitude of wind velocity

The angles of the three transducer axes relative to the anemometer's u, v, w axes are:

θ_1 = Azimuth angle of axis 1, measured clockwise from u axis
 (0 degrees)

θ_2 = Azimuth angle of axis 2, measured clockwise from u axis
 (120 degrees)

θ_3 = Azimuth angle of axis 3, measured clockwise from u axis
 (240 degrees)

ϕ = Elevation angle of all axes measured up from horizontal
 (45 degrees for R3 and R3A, 48.75 degrees for HS)

For each measurement axis the magnitude of the wind velocity component normal to the axis is equal to the magnitude of the vector product of velocity with the unit vectors in line with the axis. The three unit vectors in line with the measurement axes are:

$$\text{unit}_1 = \begin{bmatrix} \cos\theta_1 \cos\phi \\ -\sin\theta_1 \cos\phi \\ \sin\phi \end{bmatrix} \quad 11$$

$$\text{unit}_2 = \begin{bmatrix} \cos\theta_2 \cos\phi \\ -\sin\theta_2 \cos\phi \\ \sin\phi \end{bmatrix} \quad 12$$

$$\text{unit}_3 = \begin{bmatrix} \cos\theta_3 \cos\phi \\ -\sin\theta_3 \cos\phi \\ \sin\phi \end{bmatrix} \quad 13$$

Substituting the expressions for the velocity components normal to the three transducer axes into equation (8) gives the following equation for the crosswind correction term:

Sonic temperature measurement

Document No. 12100009/C

Page 6 of 7

$$T_{\text{cross}} = \frac{1}{3} \times \frac{1}{403} (|\text{velocity} \times \text{unit}_1|^2 + |\text{velocity} \times \text{unit}_2|^2 + |\text{velocity} \times \text{unit}_3|^2) \quad (14)$$

The square of the magnitude of a vector is equal to the scalar product of the vector with itself. Using this relationship the crosswind correction term becomes:

$$T_{\text{cross}} = \frac{1}{3} \times \frac{1}{403} ((\text{velocity} \times \text{unit}_1) (\text{velocity} \times \text{unit}_1) + (\text{velocity} \times \text{unit}_2) (\text{velocity} \times \text{unit}_2) + (\text{velocity} \times \text{unit}_3) (\text{velocity} \times \text{unit}_3)) \quad (15)$$

To find the expression for the crosswind correction term substitute equations (10), (11), (12) and (13) into equation (15) and simplify the result. The intermediate calculations are not reproduced in this document because they take up a lot of space. To minimise the risk of errors in the calculation, the solution was found using the "Maple symbolic engine" included in "Mathcad PLUS 5.0". The solution is:

$$T_{\text{cross}} = \frac{|\text{velocity}|^2}{403} \left[\cos^2\phi + \cos^2\phi_w - \frac{3}{2} \cos^2\phi \cos^2\phi_w \right] \quad (16)$$

This can be expressed in terms of the u, v and w velocity components by making the substitutions:

$$|\text{velocity}|^2 = u^2 + v^2 + w^2 \quad (17)$$

$$\cos^2\phi_w = \frac{u^2 + v^2}{u^2 + v^2 + w^2} \quad (18)$$

Which gives the following result:

$$T_{\text{cross}} = \frac{1}{403} \left[(u^2 + v^2) \left(1 - \frac{1}{2} \cos^2\phi \right) + w^2 \cos^2\phi \right] \quad (19)$$

Substituting this expression for the crosswind correction term back into equation (7) results in the following equation for sonic temperature averaged over three measurement axes, with crosswind correction applied:

Sonic temperature measurement

Document No. 12100009/C

Page 7 of 7

$$T_s \text{ (corrected)} = \frac{1}{403} \left[\left(\frac{c_1^2 + c_2^2 + c_3^2}{3} \right) + (u^2 + v^2) \left(1 - \frac{1}{2} \cos^2 \phi \right) + w^2 \cos^2 \phi \right] \quad (20)$$

The elevation angle of the transducer paths, ϕ , is a constant. It is 45° for the R3 and R3A anemometers, and 48.75° for the HS. Thus for each head design the crosswind correction term for data averaged over three axes is a weighted sum of squares of the u, v and w wind velocity components. This is a simple calculation which can easily be carried out in the anemometer in real time. For example when $\phi=45^\circ$ the sonic temperature is:

$$T_s \text{ (corrected)} = \frac{1}{403} \left[\left(\frac{c_1^2 + c_2^2 + c_3^2}{3} \right) + 0.75u^2 + 0.75v^2 + 0.5w^2 \right] \quad (21)$$

If the R3, R3A or HS anemometer is configured to output sonic temperature then the value it produces is corrected for cross-wind according to equation (20). If it is configured to output speed of sound then the anemometer first calculates cross-wind corrected sonic temperature according to equation (20) and then converts this into a speed of sound value by substituting the sonic temperature into equation (2).

REFERENCES

- (1) JC Kaimal and JE Gaynor
Another look at sonic thermometry
Boundary-Layer Meteorology 56: 401-410, 1991

APPENDIX D

Micro-Met Calculations

Micro-Met Calculations

Micro-met Calculations

1231-0002/C

Inputs

Results are calculated from the following raw data:

- U, V, W - Orthogonal components of the wind vector (ms⁻¹).
 T - Temperature (K).
 a₁, a₂, a₃, a₄, a₅, a₆ - analogue inputs.

The results are averaged over n samples.

Means

$$\text{Mean } U = \bar{U} = \frac{1}{n} \sum_{i=1}^n U_i$$

$$\text{Mean } V = \bar{V} = \frac{1}{n} \sum_{i=1}^n V_i$$

$$\text{Mean } W = \bar{W} = \frac{1}{n} \sum_{i=1}^n W_i$$

$$\text{Mean } T = \bar{T} = \frac{1}{n} \sum_{i=1}^n T_i$$

$$\text{Mean } AIp_j = \bar{a}_j = \frac{1}{n} \sum_{i=1}^n a_{ji}$$

Micro-Met Calculations

Variance

A wind variable (A) can be expressed as the sum of mean (\bar{A}) and turbulent (A') parts.

The variance of a the parameter (σ_A^2) is equal to the mean of the square of the turbulent (A') part ($\overline{A'^2}$), and is defined as:

$$\begin{aligned}\sigma_A^2 &= \frac{1}{n} \sum_{i=1}^n (A_i - \bar{A})^2 \\ &= \frac{1}{n} \sum_{i=1}^n A_i^2 - \bar{A}^2\end{aligned}$$

The standard deviation of A (σ_A) is the square root of the variance:

$$\begin{aligned}\sigma_A &= \sqrt{\frac{1}{n} \sum_{i=1}^n A_i^2 - \bar{A}^2} \\ U_{sig} = \sigma_U &= \sqrt{\frac{1}{n} \sum_{i=1}^n U_i^2 - \bar{U}^2} \\ V_{sig} = \sigma_V &= \sqrt{\frac{1}{n} \sum_{i=1}^n V_i^2 - \bar{V}^2} \\ W_{sig} = \sigma_W &= \sqrt{\frac{1}{n} \sum_{i=1}^n W_i^2 - \bar{W}^2} \\ T_{sig} = \sigma_T &= \sqrt{\frac{1}{n} \sum_{i=1}^n T_i^2 - \bar{T}^2} \\ Alp_j sig = \sigma_{a_j} &= \sqrt{\frac{1}{n} \sum_{i=1}^n a_{ji}^2 - \bar{a}_j^2}\end{aligned}$$

Micro-Met Calculations

Covariance

$$UVcov = \overline{U'V'} = \frac{1}{n} \sum_{i=1}^n U_i V_i - \bar{U} \bar{V}$$

$$UWcov = \overline{U'W'} = \frac{1}{n} \sum_{i=1}^n U_i W_i - \bar{U} \bar{W}$$

$$VWcov = \overline{V'W'} = \frac{1}{n} \sum_{i=1}^n V_i W_i - \bar{V} \bar{W}$$

$$UTcov = \overline{U'T'} = \frac{1}{n} \sum_{i=1}^n U_i T_i - \bar{U} \bar{T}$$

$$VTcov = \overline{V'T'} = \frac{1}{n} \sum_{i=1}^n V_i T_i - \bar{V} \bar{T}$$

$$WTcov = \overline{W'T'} = \frac{1}{n} \sum_{i=1}^n W_i T_i - \bar{W} \bar{T}$$

$$AIp_j Wcov = \overline{a_j'W'} = \frac{1}{n} \sum_{i=1}^n a_{ji} W_i - \bar{a}_j \bar{W}$$

Micro-Met Calculations

Wind Components in the Natural Coordinate System

The wind parameters in the anemometers frame of reference is translated to a natural coordinate system parallel and orthogonal to the mean wind vector.

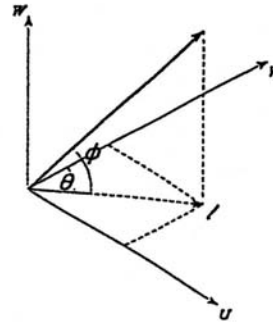

Where

$$xsig = \sigma_x = \sqrt{\overline{l'^2} \cos^2 \phi + 2\overline{l'w'} \sin \phi \cos \phi + \overline{w'^2} \sin^2 \phi}$$

$$ysig = \sigma_y = \sqrt{\overline{v'^2} \sin^2 \theta - 2\overline{u'v'} \sin \theta \cos \theta + \overline{u'^2} \cos^2 \theta}$$

$$zsig = \sigma_z = \sqrt{\overline{l'^2} \sin^2 \phi - 2\overline{l'w'} \sin \phi \cos \phi + \overline{w'^2} \cos^2 \phi}$$

$$\overline{l'w'} = \overline{u'w'} \sin \theta + \overline{v'w'} \cos \theta$$

$$\overline{l'^2} = \overline{(u' \sin \theta + v' \cos \theta)^2}$$

$$\sin \theta = \frac{\overline{U}}{\sqrt{\overline{U}^2 + \overline{V}^2}} \quad \cos \theta = \frac{\overline{V}}{\sqrt{\overline{U}^2 + \overline{V}^2}}$$

$$\sin \phi = \frac{\overline{W}}{\sqrt{\overline{U}^2 + \overline{V}^2 + \overline{W}^2}} \quad \cos \phi = \frac{\sqrt{\overline{U}^2 + \overline{V}^2}}{\sqrt{\overline{U}^2 + \overline{V}^2 + \overline{W}^2}}$$

$$l = U \sin \theta + V \cos \theta$$

Micro-Met Calculations

Turbulence Parameters**Longitudinal turbulence intensity**

$$t_x = \frac{\sigma_x}{\overline{M}}$$

Transversal turbulence intensity

$$t_y = \frac{\sigma_y}{\overline{M}}$$

Vertical turbulence intensity

$$t_z = \frac{\sigma_z}{\overline{M}}$$

Where

$$\overline{M} = \sqrt{\overline{U}^2 + \overline{V}^2 + \overline{W}^2}$$

Friction Velocity

$$u_* = \sqrt{\overline{l'w'}(2\sin^2\phi - 1) + (\overline{l'^2} - \overline{w'^2})\sin\phi\cos\phi}$$

Characteristic Temperature

$$T_* = \frac{\overline{w'T'}}{u_*}$$

Micro-Met Calculations

Drag Coefficient

$$C_D = \frac{u_*^2}{M^2}$$

Obukhov Length

$$L = \frac{-\bar{T} u_*^3}{Kg \overline{W'T'}}$$

Where :

K = von Kármán constant

g = acceleration due to gravity

Momentum Flux

$$F = -\rho u_*^2$$

Where:

ρ = specific density of air

Heat Flux

$$Q_H = c_p \rho \overline{W'T'}$$

Where:

c_p = Specific heat of air at constant pressure

Mean Turbulence Kinetic Energy per unit mass

$$\bar{e} = \frac{1}{2}(\overline{U'^2} + \overline{V'^2} + \overline{W'^2})$$

APPENDIX E

RCOM Binary File Format

1. Binary File Header

Description		Number of bytes	Usual data type	Comments
file_type	1	unsigned char		0=ASCII tabular, 1=Binary tabular, 2=ASCII micro-met 3=Binary micro-met
file_version	1	unsigned char		Numeric
type	1	unsigned char		O=R3 or R3A, H = HS, S= Single axis
serial_number	4	unsigned long		Numeric
average	1	unsigned char		Numeric, 1 to 250.
wind_report_mode	1	unsigned char		0=UVW cal, 1= UVW uncal, 2=Polar cal, 3= Polar uncal, 4 = axis
string_format	1	unsigned char		0 = Binary, 1= ASCII pad, 2= ASCII unpad
ascii_terminator	1	unsigned char		0 = CR, 1= CRLF
echo	1	unsigned char		0 = off, 1 = on
message_mode	1	unsigned char		0 = continuous, 1 = polled
confidence tone setting	1	unsigned char		0 = on, 1 = off, 2 = disabled
axis alignment setting	1	unsigned char		0 = axis, 1= spar
speed_of_sound_report_mode	1	unsigned char		0 = off, 1= speed, 2=sonictemp K, 3=sonictemp C
absolute_temperature_report_mode	1	unsigned char		0= off, 1 = K, 2 = °C
analogue_input_1_on	1	unsigned char		0 = off, 1 = on
analogue_input_2_on	1	unsigned char		“
analogue_input_3_on	1	unsigned char		“
analogue_input_4_on	1	unsigned char		“
analogue_input_5_on	1	unsigned char		“
analogue_input_6_on	1	unsigned char		“

analogue_output_scale	1	unsigned char	0=10m/s, 1= 20m/s, 2= 30m/s, 3= 60m/s
analogue_output_wrap	1	unsigned char	0 = 360°, 1= 540°
file create time	4	unsigned long	file create time in seconds since 00:00:00 GMT, January 1970

2. Binary Data

Description		Number of bytes	Usual data type	Comments
data valid / invalid	1	unsigned char		0=valid string, 1=otherwise invalid string, 2=checksum error 3=checksum error and invalid string
U or direction or axis velocity 1	2	short int		velocity in 0.01m/s, direction in degrees
V or magnitude or axis velocity 2	2	short int		velocity in 0.01m/s
W or axis speed 3	2	short int		velocity in 0.01m/s
Reserved	4			
Reserved	4			
anemometer status	1	unsigned char		
anemometer status address	1	unsigned char		
absolute temperature	2	unsigned short int or short int		0.01K increments (unsigned) 0.01°C increments (signed)
speed of sound / sonic temperature	2	unsigned short int or short int		in 0.01m/s or 0.01K increments (unsigned) 0.01°C increments (signed)
analogue input 1	4	long		analogue input
analogue input 2	4	long		“
analogue input 3	4	long		”
analogue input 4	4	long		”
analogue input 5	4	long		”
analogue input 6	4	long		”
clino_x	2	short int		in 0.01° increments
clino_y	2	short int		in 0.01° increments

Notes On Binary File Format

Analogue Inputs

If the anemometer output string format is ASCII the analogue inputs are stored in the binary file in 100uV increments from -5V to +5V.

If the anemometer output string format is binary then analogue inputs are stored in the binary file as follows:-

Voltage	Analogue Input Value
+ 4.9994	8191
0.0000	0000
- 5.0000	-8192

Gill Instruments Ltd

Terms of Guarantee

This Guarantee is in addition to and does not in any way affect any statutory or other legal rights including but not limited to the purchaser's right to redress if the equipment is not a) as described, b) of satisfactory quality or c) fit for its purpose.

If within the applicable guarantee period (as shown in 10 below) the equipment proves to be defective by reason of faulty design, workmanship or materials, we undertake subject to the following terms to have the defective equipment (or any parts thereof) repaired or at our discretion replaced free of charge.

1. The equipment shall have been purchased and used solely in accordance with standard operating instructions supplied with the equipment and the technical and/or safety standards required in the country where the equipment is to be used.
2. The equipment should be returned, together with proof of purchase, promptly on being found defective, at the purchaser's risk and expense to the authorised distributor, from whom the appliance was purchased or to Gill Instruments Limited if purchased from us. All initial enquiries must be made through the authorised distributor except in cases where purchase was from us.
3. This Guarantee shall not apply to damage caused through fire, accident, misuse, wear and tear, neglect, incorrect adjustment or repair, to damage caused through installation, adaptation, modifications, or use in an improper manner or inconsistent with the operating instructions supplied with the equipment or the technical and/or safety standards required in the country where the equipment is used, or to damage occurring during transit to or from the purchaser.
4. If at any time during the Guarantee period any parts or parts of the equipment are replaced with a part or parts not supplied or approved by us, or the equipment has been dismantled or repaired by a person not authorised by us, the purchaser shall not be entitled to any rights and/or remedies under this guarantee.
5. Under this Guarantee we will repair, at our discretion, replace defective equipment or any part or parts and this shall be the limit of liability under this Guarantee.
6. Some product models may require adjustment and/or adaptation for proper performance and safe use in countries other than the United Kingdom, in accordance with local voltage requirements and safety or other technical standards imposed or recommended by applicable regulations. For certain product models, the cost of such adjustment or adaptation may be substantial and it may be difficult to satisfy local voltage requirements and safety or other technical standards. It is strongly recommended that the purchaser investigate these local technical and safety factors before using the appliance outside the United Kingdom.
7. This Guarantee shall not cover the cost of any adjustment or adaptations to meet local voltage requirements and safety or other technical standards outside the United Kingdom where these differ from those applicable in the United Kingdom.
8. This Guarantee shall not apply to batteries or any other parts with a limited natural life.
9. Our decision on all matters relating to complaints shall be final. Any appliance or defective part which has been replaced by us shall become our property.
10. The Guarantee period applicable to all equipment shall be 12 months from despatch of the equipment, except when term 11 below applies.
11. The warranty will be extended to 18 months from the despatch of the equipment following receipt by us of a properly completed warranty card taken from the User Manual supplied with the equipment.
12. Any repaired or replaced equipment shall be re-delivered to the (authorised distributor from whom the equipment was purchased). You must arrange collection through the authorised distributor. (Where equipment was purchased from us you must make such arrangements with us).
13. Any repaired or replaced equipment shall be subject to this Guarantee (save that, in relation to repaired equipment, the period of either 12 months in accordance with term 10 or 18 months in accordance with term 11 shall be replaced by the expired portion of the relevant period only).