



WindObserver II
Ultrasonic Anemometer
(Pipe Mount)
Part 1390-PK-042

User Manual

Doc No. 1390-PS-0009
Issue 04

Gill Instruments Limited

Saltmarsh Park,
67 Gosport Street,
Lymington,
Hampshire.
SO41 9EG
UK

Tel: +44 (0) 1590 613500
Fax: +44 (0) 1590 613501



Figure 1. WindObserver II Anemometer (Pipe Mount)

Contents

1.	FOREWORD.....	5
2.	INTRODUCTION.....	5
3.	FAST TRACK SET-UP	5
4.	SPECIFICATION	6
5.	PRE-INSTALLATION	7
5.1.	Equipment supplied	7
5.2.	Installation requirements.....	7
6.	INSTALLATION.....	8
6.1.	Installation Guidelines.....	8
6.2.	Bench system test	9
6.3.	Cabling	9
6.4	. Connections.....	10
	Factory Default Output Settings.....	10
	Connecting to a PC with a RS422 or RS485 input	11
	Networking units.....	12
	Connecting to a PCI Unit with RS422 input.....	13
	Indoor Power and Communications Interface (Part 1189-PK-021).....	13
	PCI Electrical Power Requirements	13
	PCI Connector Pin and Cable assignments	14
	Anemometer connector – 15 way	14
	Auxiliary Analogue Outputs – 9 way (not applicable to Pipe Mount unit).....	14
	DC Supply – 4 way.....	14
	RS 232 Output – 9 way	15
	RS422 Network In – 9 way Skt	15
	RS422 Network Out – 9 way Plg.....	15
6.5.	Mechanical installation.....	16
	Location	16
	Orientation	16
	Mounting bracket.....	16
6.6.	Power supplies	16
	Alignment.....	17
7	USING WITH THE GILL WINDDISPLAY	18
	Connecting to a Gill WindDisplay.....	19
8	MESSAGE FORMATS & OPTIONS.....	20
8.1.	Wind Speed format	20
8.2.	Output formats.....	20
	Low wind speeds.....	20
8.3.	Networking.....	20
8.4.	Units	21
8.5.	Output rate.....	22
	Sample Average.....	22
8.6.	Averaging	22
8.7.	Options	22
	Speed of Sound (SOS) and Temperature	22
	Heating	22
	45° Offset.....	22
	Vertical Output Padding.....	22
8.8.	ASCII message format (UV and Polar)	23

	ASCII UV format.....	23
	ASCII Polar format	24
	ASCII Polled (UV and Polar).....	24
8.9.	Binary message format (UV, Polar and Tunnel).....	25
	Binary UV format.....	25
	Binary Polar format.....	26
	Binary Tunnel format.....	26
8.10.	NMEA Format.....	27
9.	CONFIGURING.....	28
9.1	Configuring using HyperTerminal.....	28
9.2	Entering Configuration mode	28
9.3	Returning to Measurement mode.....	28
9.4	Checking the configuration	29
9.5.	Changing settings.....	29
9.6.	Configuration Settings.....	30
	Ax – Speed of Sound (SOS) and Temperature	30
	BX - Baud Rate	30
	Cx – Not Applicable.....	30
	Dx – Diagnostic and Configuration Command.....	31
	Ex - Duplex mode.....	31
	Fx - Data and parity options.....	31
	Gx to Gxxx – Averaging (Digital Outputs Only)	31
	Hx - Heating	32
	Jx – Not Applicable.....	32
	Kx – NMEA Settings.....	32
	Lx - ASCII Message terminator.....	32
	Mx to MXX – Message Format	32
	Nx - Node Address	33
	Ox – ASCII Output Format (Output String Padding).....	33
	Px - Output rate.....	33
	Q – Measurement Mode.....	33
	Tx – Not Applicable.	33
	Ux – Digital Output Units	33
	Vx - Vertical Output Padding	34
	Xx - 45° Alignment Offset/Inverted Operation.....	34
	Yx - Not Applicable.....	34
	Zx – Not Applicable.	34
10.	MAINTENANCE & FAULT-FINDING	35
10.1	. Cleaning	35
10.2.	Servicing.....	35
10.3.	Fault-finding.....	35
10.4.	Returning unit	36
10.5	. Status (error) codes	36
10.6.	Bench test.....	36
	Integrity Check Chamber (ICC).....	37
	Integrity & Zero Wind Check.....	37
11.	APPENDICES.....	38
11.1	. Glossary & Abbreviations.....	38
11.2	. Guarantee.....	39
11.3	. Principle of operation	40
11.4	. Electrical Conformity	41
	EC DECLARATION OF CONFORMITY ACCORDING.....	41

1. FOREWORD

Thank you for purchasing the WindObserver II (Pipe Mount) manufactured by Gill Instruments Ltd.

The unit has no customer serviceable parts and requires no calibration or maintenance. To achieve optimum performance we recommend that you read the whole of this manual before proceeding with use. Do **NOT** remove black “rubber” transducer caps.

Gill products are in continuous development and therefore specifications may be subject to change and design improvements without prior notice.

The information contained in this manual remains the property of Gill Instruments and should not be copied or reproduced for commercial gain.

2. INTRODUCTION

The Gill WindObserver II (Pipe Mount) wind sensor is a very robust, lightweight unit with no moving parts, outputting wind speed and direction. The units of wind speed, output rate and formats are all user selectable.

The WindObserver II (Pipe Mount) is supplied with de-icing heating on (recommended if icing is likely).

The WindObserver II (Pipe Mount) can be used in conjunction with a PC, data-logger or other device, provided it is compatible with the RS422 output. Multiple units can be networked if required.

Alternatively, the WindObserver II (Pipe Mount) is designed to connect directly to the Gill WindDisplay unit to provide a complete wind speed direction system without any configuration required by the user.

The output message format can be configured in Polar, UV (2-axis), NMEA (0183 Version 3), Tunnel formats, and as either a Continuous output or Polled (requested by host system), detailed in full in Section 8 Message Formats & Options.

WindObserver II (Pipe Mount) may be configured using WindCom software which is available, free of charge, from the Gill website www.gill.co.uk, or by using standard communications software on a PC. This is explained in Section 9 Configuring.

3. FAST TRACK SET-UP

If you are in a hurry to try out the WindObserver II (Pipe Mount), are familiar with Gill equipment, and coupling to a PC using RS422, go to the following sections:

Section 6 Installation

Section 8 Message Formats & Options

Section 9 Configuring

After you have successfully set up the WindObserver II (Pipe Mount), we strongly advise that you then go back and read the rest of the manual to ensure that you get the best results from the WindObserver II (Pipe Mount).

4. SPECIFICATION

Measurement

Output	1, 2, 4, 5, 8, 10Hz
Parameters	UV, Polar, NMEA, Tunnel
Units	m/s, Knots, MPH, KPH ft/min
Averaging	Flexible 1-3600 seconds

Wind Speed

Range	0 - 65m/s (0-145mph)
Accuracy	2%
Resolution	0.01m/s
Offset	±0.01m/s

Direction

Range	0 - 359°
Accuracy	± 2°
Resolution	1°

Sonic Temperature Output

Range	-40°C to + 70°C
-------	-----------------

Anemometer Status

Supplied as part of standard message

Starting Threshold

0.01 m/s

Dead Band Wind Direction

None

Power Requirement

Anemometer only	9-30 V DC (40mA @ 12VDC)
Heating - Optional	Allow 3A @ 22v to 30v max AC rms or DC

Digital Output

Communication	RS422, full duplex, network facility
Baud rates	1200, 2400, 4800, 9600, 19200, 38400
Formats	8 data, odd, even or no parity

Dimensions

Size	405mm x 210mm
Weight	1.5kg

Materials

External Construction	Stainless Steel 316
-----------------------	---------------------

Environmental

Moisture protection	IP66 (NEMA4X)
Operating temperature	-55°C to +70°C (heated version)
Humidity	0% to 100% RH
Precipitation	300mm/hr
EMC	BS EN 50081-1: 1992 (Emissions class B) BS EN 50082-2: 1992 (Immunity) FCC class A

Icing	MILSTD810E Method 521.1 Procedure 1
-------	-------------------------------------

Standards

Traceable to UK national standards

Site Calibration

None required. (See Section 10.6 Zero Wind Check)

5. PRE-INSTALLATION

5.1. Equipment supplied

- WindObserver II (Pipe Mount) RS422 output and de-icing
- and Installation kit
- and WindObserver II (Pipe Mount) User Manual (this manual)
- and Integrity Check Chamber (ICC) (Optional)

5.2. Installation requirements

Host system - One of the following:

- PC with an internal or external interface compatible with the RS422 output from the WindObserver II (Pipe Mount).
- Networking - Multiple WindObserver II (Pipe Mount) units can be networked

Software - One of the following:

- WindCom – A user-friendly package providing easy configuring of the WindObserver II (Pipe Mount), for use on PCs running under Windows™ 98, 2000 or XP. Available to customers as a free download from www.gill.co.uk.
- HyperTerminal (for Windows™ 9x and later), or Terminal (Windows™ 3.n), normally already installed on a PC.
- Other Terminal Emulation software packages

Cable and Junction box

To connect between the WindObserver II (Pipe Mount) and the host system. The unit is supplied with a 4 metre flying unterminated cable.

See Section 6.4 for connection details

Mounting Pole

The WindObserver II (Pipe Mount) is designed to mount on a pole of nominal pipe size diameter 50mm (*See Fig 2. Page 17*).

6. INSTALLATION

Do NOT remove the black “rubber” transducer caps. Warranty is void if the blue security seal is damaged or removed.

All the time the WindObserver II (Pipe Mount) is not in its final location, it should be protected from damage by keeping it in the original packaging as long as possible, treating it as a delicate instrument.

If an Intrinsically Safe (IS) device is required, the I.S. WindObserver must be used - the WindObserver II (Pipe Mount) is NOT an IS device.

6.1. Installation Guidelines

The WindObserver II (Pipe Mount) has been designed to meet and exceed the stringent standards listed in its specification. Operating in diverse environments all over the world, WindObserver II (Pipe Mount) requires no calibration or adjustment whatsoever.

As with any sophisticated electronics, good engineering practice should be followed to ensure correct operation.

- Always check the installation to ensure the WindObserver II (Pipe Mount) is not affected by other equipment operating locally, which may not conform to current standards, e.g. radio/radar transmitters, boat engines, generators etc.

Guidelines –

- Avoid mounting in the plane of any radar scanner – a vertical separation of at least 2m should be achieved.
- Radio transmitting antennas, the following minimum separations (all round) are suggested
 - VHF IMM – 1m
 - MF/HF – 5m
 - Satcom – 5m (avoid likely lines of sight)
- Ensure the product is correctly earthed in accordance with this manual
- Use cables recommended by Gill, keeping the length below the maximum allowed (*See Section 6.3*) Where the cables are cut and re-connected (junction boxes, plugs and sockets) the cable screen integrity must be maintained, to prevent the EMC performance being compromised.
- Earth loops should not be created – earth the system in accordance with the installation guidelines. (*See Section 6.4*)
- Ensure the power supply operates to the WindObserver II (Pipe Mount) specification at all times.

Avoid turbulence caused by surrounding structures that will affect the accuracy of the WindObserver II (Pipe Mount) such as trees, masts and buildings. The World Meteorological Organisation makes the following recommendation:

- The standard exposure of wind instruments over level open terrain is 10m above the ground. Open terrain is defined as an area where the distance between the sensor and any obstruction is at least 10 times the height of the obstruction.

6.2. Bench system test

Note: Prior to physically mounting the WindObserver II (Pipe Mount) in its final location, we strongly recommend that a bench system test be carried out to confirm the system is configured correctly, is fully functional and electrically compatible with the selected host system and cabling (preferably utilising the final cable length). The required data format, units, output rate, and other options should also all be configured at this stage. If an Integrity Check Chamber (ICC) has been purchased refer to Section 10.6.

6.3. Cabling

Cable type

A RS422 compatible cable should be used, with the number of twisted pairs matching the application.

Generic description

No. of pairs	Gill ref.	Belden ref.	Batt Electronics
6	026-03508	9806	91021

Cable length

The typical maximum length at 9600 baud is 1km using the recommended cable. If any problems of data corruption are experienced (due to, for example, a high local electrical 'noise' level), then a lower baud rate should be used. Alternatively, a thicker or higher specification cable can be tried. . If a heated unit is used on longer cables than supplied, consideration should be given to powering the heater using lower gauge wire or paralleling wires to reduce volt drops.

Cabling and junction box

The WindObserver II (Pipe Mount) unit is fitted with a flying 6 pair cable attached (4 metre long). This must be terminated in a suitable manner to prevent moisture ingress. If any cable is likely to be exposed to mechanical damage, it must be enclosed in a suitable conduit or cable tray. The cable must be securely fixed with cable clamps or equivalent at regular intervals such that the WindObserver cable gland does not support the cable weight.

The gland area at the base of the WindObserver II (Pipe Mount) **should not** be directly exposed to moisture, as whilst the gland is sealed when mated, the anemometer is vented to air at the base to avoid pressure build up.

6.4. Connections

Important Do NOT join any of the cores of the cable together. Joining cores could damage the unit permanently. Any cores not used should be isolated.

Do NOT connect the unit's 0V, heating -ve or digital 0V to the screen or earth.

The screens of each pair are joined together inside the anemometer - these should be joined to the cable screen(s) of any further cable run. Avoid long grounding loops. Digital 0V should be used in conjunction with RS422 TX RX lines in order to improve noise immunity.

Conductor colour		Designation
Pair 1	green	RS422_TXB (+)
	black	RS422_TXA (-)
Pair 2	white	RS422_RXB (+)
	black	RS422_RXA (-)
Pair 3	red	Supply V+
	black	Supply V-
Pair 4	blue	Digital 0v
	black	Not used (isolate)
Pair 5	yellow	Heater +
	black	Heater -
Pair 5	brown	Heater +
	black	Heater -
Screens		Chassis ground

Earthing or grounding

To ensure correct operation, and for maximum protection against lightning, the anemometer **MUST** be correctly earthed (grounded) via its mountings. Inadequate Earthing will degrade anemometer performance, particularly in the presence of radio frequency interference.

The unit **MUST** be connected to an appropriate grounding point with a minimum of 6mm² copper wire, via the M8 base screw. The cable screens must be joined with any cable screen continuing from the unit's cable via a junction box. The primary earth for the anemometer must be provided via the base screws and not via the cable screens. See Fig.2.

Factory Default Output Settings

The factory default settings are:

A0 B3 C1 E1 F1 G0000 H2 J1 K1 L1 M2 NA O2 P5 T1 U1 V1 X2 Y1 Z1

Connecting to a PC with a RS422 or RS485 input

The PC requires either an internal RS422 interface card, or an external RS422/485 to RS232 converter, which will plug into the standard 9 way or 25 way RS232 serial port of the PC or host equipment.

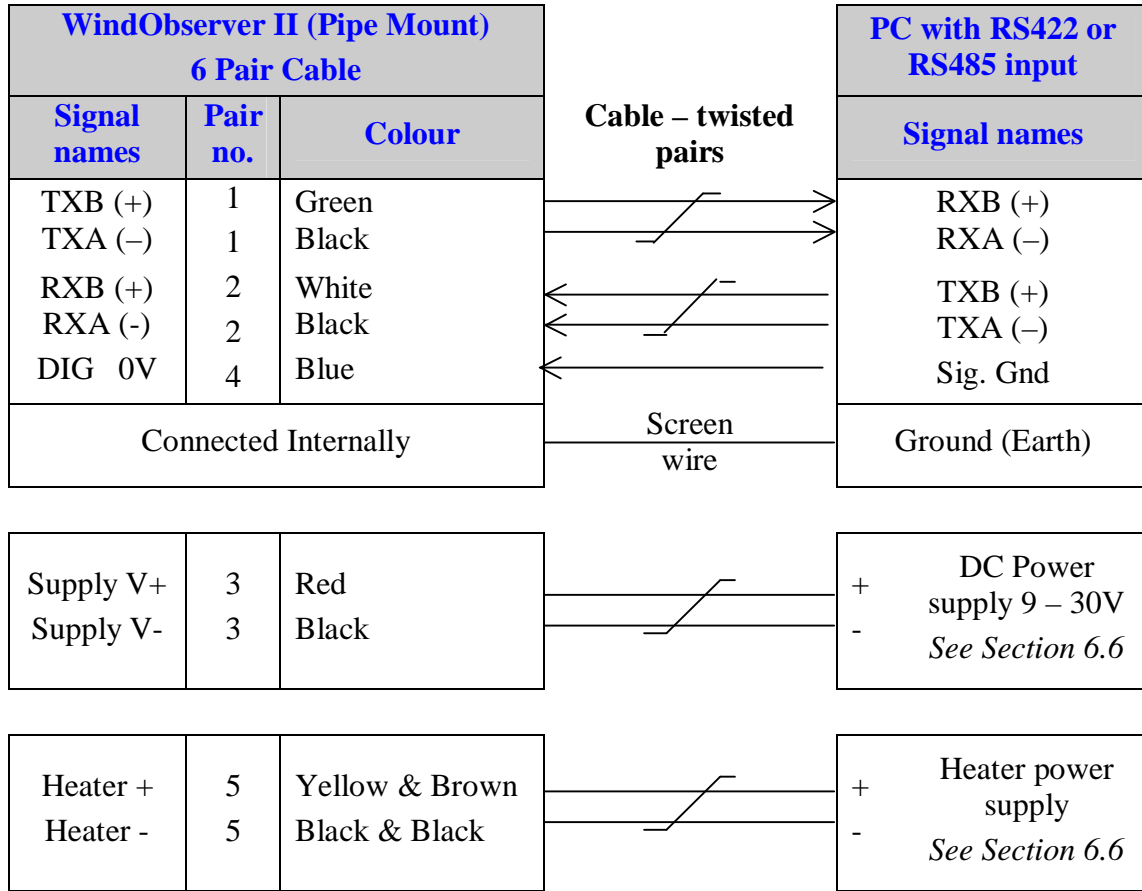

Networking units

Before coupling units into a network:

- Each device must be configured with a unique Unit Identifier (letter B to Z)
- It must be configured to a tri-state polled mode [M3](#) or [M4](#).

See Section 9 - Configuring

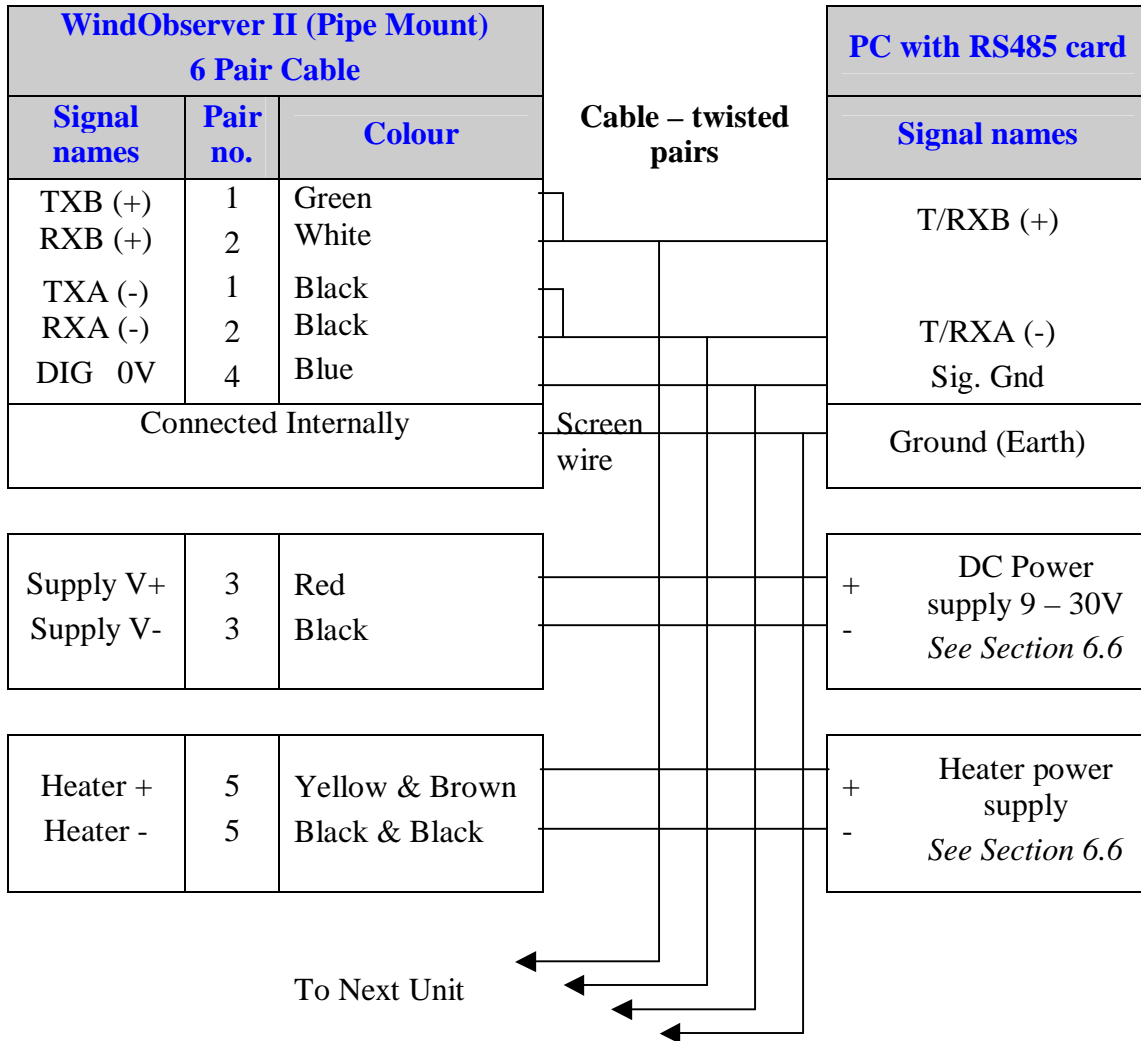

Note: Each unit in the network will require its own power supplies.
Please refer to section 8.3.

Connecting to a PCI Unit with RS422 input

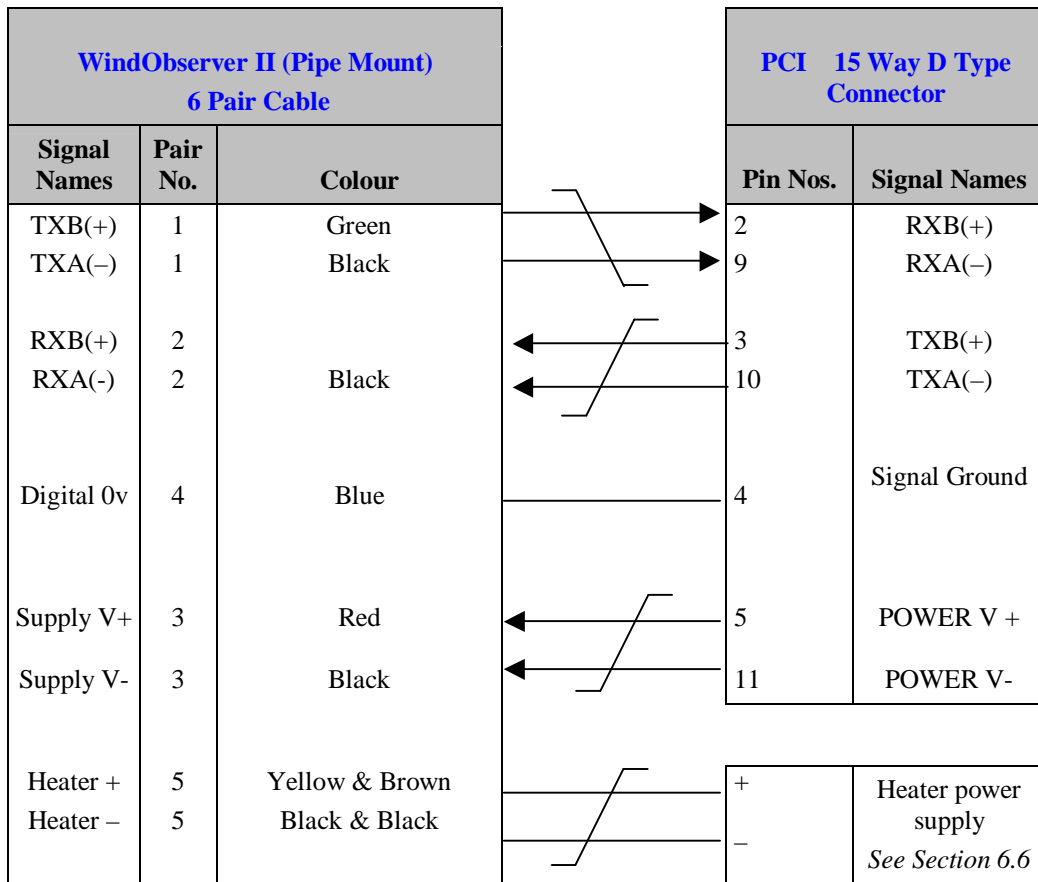

Indoor Power and Communications Interface (Part 1189-PK-021)

Environmental

The desktop PCI is intended for use in a protected environment and provides interfacing to a single anemometer. The PCI is not intended for outdoor use.

PCI Electrical Power Requirements

- 1) 100Vac – 120Vac, 10VA for the 115V switch position
- 2) 200 Vac – 250Vac, 10VA for the 230V switch position
- 3) 9-30Vdc, 120mA max (anemometer)
8-15Vdc, 50mA max (interface)

3 Fuses protect the unit:

1. Externally accessible 315mA(T) for 115/230v operation
2. Internally accessible 500mA (T) AUX
500mA (T) ANEM

PCI Connector Pin and Cable assignments

Anemometer connector – 15 way

Pin	Designation
1	Chassis
2	RS422_RXB (+)
3	RS422_TXB (+)
4	Digital 0V, Signal ground
5	Supply V+
6	Not used
7	Not used
8	Not Used
9	RS422_RXA (-)
10	RS422_TXA (-)
11	Supply V-
12	Not used
13	Not Used
14	Not used
15	Not used

Auxiliary Analogue Outputs – 9 way (not applicable to Pipe Mount unit)

Pin	Designation
1	Earth
2	Analogue Ground 1
3	Analogue Ground 2
4	Analogue Ground 3
5	Analogue Ground 4
6	Analogue Output 1
7	Analogue Output 2
8	Analogue Output 3
9	Analogue Output 4

DC Supply – 4 way

Pin	Designation
1	Interface V+
2	Interface V-
3	Anemometer V-
4	Anemometer V+

RS 232 Output – 9 way

Pin	Designation
1	DCD
2	RX data
3	TX data
4	DTR
5	Signal Ground
6	DSR
7	RTS
8	CTS
9	RI

RS422 Network In – 9 way Skt

Pin	Designation
1	Not connected
2	Not connected
3	Not connected
4	RS422_RXA (-)
5	Signal ground
6	RS422_TXA (-)
7	RS422_TXB (+)
8	RS422_RXB (+)
9	Chassis

RS422 Network Out – 9 way Plg

Pin	Designation
1	Not connected
2	Not connected
3	Not connected
4	RS422_RXA (-)
5	Signal ground
6	RS422_TXA (-)
7	RS422_TXB (+)
8	RS422_RXB (+)
9	Chassis

6.5. Mechanical installation

Before installing, a bench system test is recommended (*see Section 6.2*).

All the time the WindObserver II (Pipe Mount) is not in its final location, it should be protected from damage by keeping it in the original packaging as long as possible, treating it as a delicate instrument.

Location

It is important to ensure that the WindObserver II (Pipe Mount) is mounted in a position clear of any structure, which may obstruct the airflow or induce turbulence.

Do NOT mount the WindObserver II (Pipe Mount) in close proximity of high-powered radar or radio transmitters. A site survey may be required if there is any doubt about the strength of external electrical noise. (*See Section 6.1*)

Orientation

The WindObserver II (Pipe Mount) must be mounted vertically with the cable exit at the bottom.

Mounting bracket

It is recommended that the WindObserver II (Pipe Mount) mounting pipe be manufactured from stainless steel 316, to prevent possible galvanic corrosion.

Stainless steel 316 fixings (supplied) must be used.

6.6. Power supplies

All WindObserver II (Pipe Mount) units

Voltage	9 to 30v DC
Current	60mA max. 50mA average

Heating

Voltage	22V to 30V (max) AC RMS or DC.
Current	allow for 3A.

- **The AC Supply must be isolated from Mains Supply.**
- The heating module requires a separate power supply.
- Heater Cable length should be minimised to avoid cable volt drops and ensure maximum voltage received at the Anemometer.
- Each transducer is heated independently and will be active when ambient temperature drops below approximately +15°C each transducer will de-activate when +25°C threshold is reached.

The WindObserver II has reverse polarity protection.

Alignment

The anemometer should be set to point North (or to another known reference direction), using the North alignment indicator on the base of the instrument. *See Figure 2.*

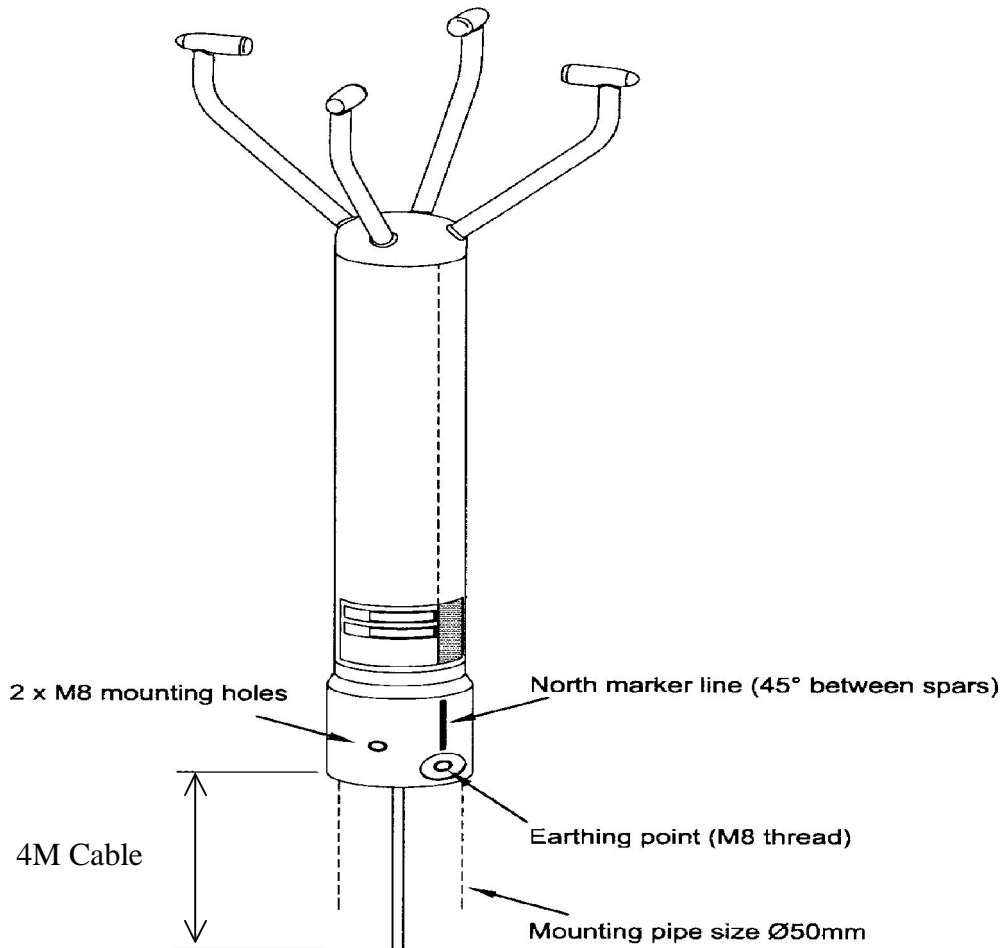

Figure 2 North marker and Mounting

(See fig. 4, on page 31 for u, v definition)

7 USING WITH THE GILL WINDDISPLAY

The WindObserver II is designed to link directly to the Gill WindDisplay unit to provide a complete wind speed and direction system.

When coupled to a WindDisplay, the WindObserver II (Pipe Mount) can be used as supplied, however if a fault occurs, the WindDisplay may lock into the last valid reading. Re-configuring the Wind Observer (Pipe Mount) to Fixed Field Output (O2) will ensure that any fault is flagged on the WindDisplay.

After coupling to a WindDisplay, the Wind Speed units and the Averaging period can be selected using the WindDisplay controls. *See the WindDisplay User Manual.*

Note that although the WindDisplay can display wind speed in various units, these are calculated within the WindDisplay. The data coming to the WindDisplay **must** be in metres/sec (the factory default output setting).

Figure 3 The WindDisplay

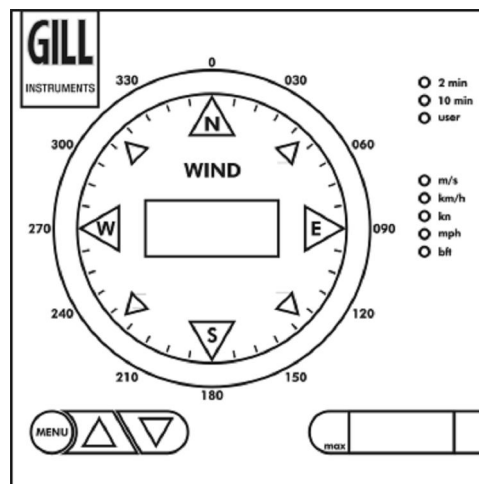

The WindDisplay has been designed to provide anemometer power (approximately 15V @40mA).

Note the WindObserver II (Pipe Mount) de-icing heater will need a separate power supply. (See *Section 6.6*).

NOTE: - If the WindDisplay is configured for NMEA mode then the WindObserver II (Pipe Mount) must also be configured for NMEA mode and 4800-baud operation (configuration settings M5 and B2).

Connecting to a Gill WindDisplay

For further details see Section 7 Using With The Gill WindDisplay, and the WindDisplay User Manual for the method of operation.

Notes

Use the WindObserver II (Pipe Mount) as supplied in the factory default settings – i.e. do not reconfigure.

The WindDisplay can provide power for the WindObserver II (Pipe Mount).

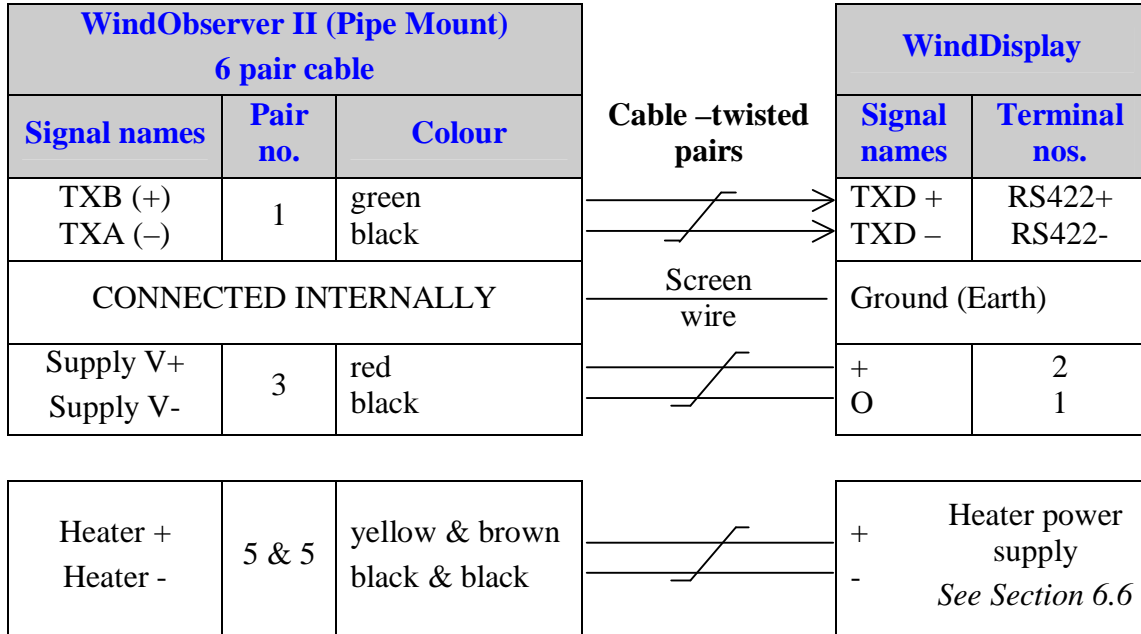

8 MESSAGE FORMATS & OPTIONS

On first applying power to the WindObserver II (Pipe Mount), it will be in 'Measurement Mode', and it will output wind measurement information in one of nine configurations as described below.

Setting the output format, units, other parameters, options and the communication settings are all carried out in the alternative 'Configuration Mode'.

See Section 9 CONFIGURING for details of how this is done.

The factory default settings are shown here in **bold**, and for convenience some 'Configuration codes' (as used to set the configuration) are shown in blue boxes.

For example [M3](#).

8.1. Wind Speed format

The wind speed measurements can be output in one of the following formats: UV, Polar, Customer formats (NMEA and Tunnel).

8.2. Output formats

The UV and Polar wind speed parameters are output in either ASCII or binary.

These parameters can be transmitted continuously or polled from the user.

Polar is also available in continuous NMEA format.

Output format		Output	Tri-state o/p	Configuration code
ASCII	UV	Continuous	No	M1
		Polled	Yes	M3
ASCII	Polar	Continuous	No	M2
		Polled	Yes	M4
Binary	UV	Continuous	No	M7
Binary	Polar	Continuous	No	M8
Binary	Tunnel	Continuous	No	M6
NMEA		Continuous	No	M5

Low wind speeds

Whilst the wind speed is below 0.05 metres/sec, the wind direction will not be calculated, in CSV mode no wind direction figure is shown, in Fixed Field mode the last known good direction figure is shown. All other output parameters will continue to update at the output rate.

8.3. Networking

Gill Proprietary Network

Each anemometer connected to the network **MUST** be given a unique Unit Identifier (Letters A to Z), and set to a polled tri-state mode (UV or Polar) ([M3](#) or [M4](#)).

In these modes the communications transmit line is tri-state unless the anemometer is responding to a command.

Configuring WindObserver II for Half Duplex Operation.

- 1) Set up Two Terminals: One for RS485 Half Duplex and the other for RS422 Full Duplex.

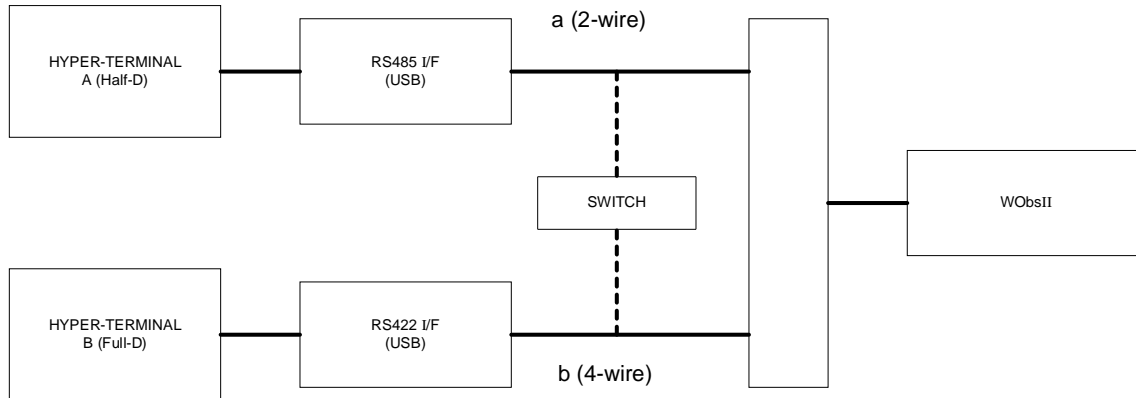

One PC (with two USB ports) can be used for both Terminals, although two may be less confusing.

Note: Power must not be disconnected from the anemometer throughout this procedure.

- 2) Assuming the unit is set for Full Duplex, connect 9-way at [b] disconnect 9-way at [a]. Set Switch to position [b] (4 wire).
- 3) On Terminal B, enter CONFIGURATION MODE. Set Half Duplex (E2). The CONFIRM> prompt will appear.
- 4) Disconnect 9-way [b] and connect 9-way [a]. Set Switch to position [a] (2 wire).
- 5) On Terminal A, type "E" <ENTER> to confirm.
- 6) The unit should now be configured in Half Duplex mode.

Configuring WindObserver II for Full Duplex Operation.

- 1) Assuming the unit is set for Half Duplex, disconnect 9-way [b] and connect 9-way [a]. Set Switch to position [a] (2 wire).
- 2) On Terminal A, type "E1" to select Full Duplex. The CONFIRM> prompt will appear.
- 3) Disconnect 9-way [a] and connect 9-way [b]. Set Switch to position [b] (4 wire).
- 4) On Terminal B type "E" <ENTER> to confirm.

8.4. Units

The wind speed can be set to any of the following units:

Unit	Abbreviation
Metres per sec	m/s
Knots	knots
Miles per hour	mph
Kilometres per hour	kph
feet per minute	fpm

8.5. Output rate

The output frequency can be set between 1 and 10 per second. The wind speed is sampled every 25ms, each axis being sampled sequentially. The following Table lists the possible outputs per second and the corresponding number of averaged samples. A 25ms sample period is used to process and output the results.

Outputs per Second	Sample Average
1	39
2	19
4	9
5	7
8	4
10	3

8.6. Averaging

The Averaging Period can be set from zero to 3600 secs. (1 hour). The default setting is zero. When averaging is enabled, data is output at a rate determined by the averaging period. The data is an average of valid data collected during the averaging period. If G is set to zero then averaging settings will be disabled.

8.7. Options

Speed of Sound (SOS) and Temperature

Either or both of these parameters can be selected or disabled

Note that neither of these parameters is available in Tunnel or NMEA formats.

SOS is useful for calculating air temperature with a rapid response. Sonic temperature is derived from the SOS, based on an assumption of the composition of the atmosphere. Humidity will affect the result.

True temperature can be calculated by:

$$T = \frac{T_s}{1+0.32 e/p}$$

Where

- T = True temperature (Kelvin)
- Ts = Sonic temperature
- e = Vapour pressure of water in air
- p = absolute pressure of water in air

Heating

Heating is autonomous and requires no set-up once activated.

45° Offset

If required, the U axis can be offset +45° to the transducer axis.

Vertical Output Padding

A dummy W vector is inserted to provide compatibility with any WindMaster that may be in a network.

8.8. ASCII message format (UV and Polar)

ASCII UV format

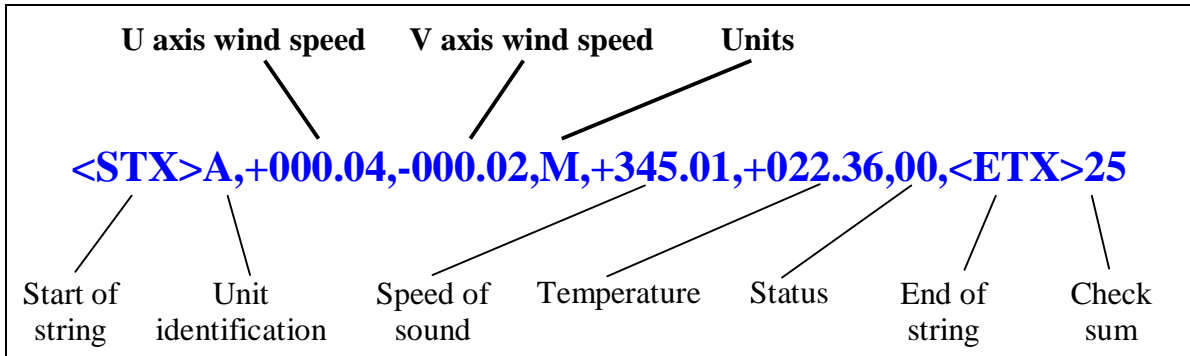

where

U axis wind speed In increments of 0.01 units (\pm UUU.UU)
V axis wind speed In increments of 0.01 units (\pm VVV.VV)

Units	Value	Units
	M	Metres per second (m/s)
	N	Knots (knots)
	P	Miles per hour (MPH)
	K	Kilometres per hour (kph)
	F	Feet per minute (fpm)

Start of string ASCII value 2
Unit identification Letter A – Z (**default A**)
Speed of sound In metres per second (if enabled)
Temperature Sonic temperature in degrees C (if enabled)

Status	Value	Status
	0	OK
	60	Heating enabled and OK if enabled
	Any other value	Warning or fault condition - see Section 10.5

End of string ASCII value 3
Check sum Exclusive OR of all characters between Start of String and End of String reported as ASCII hex.

ASCII Polar format

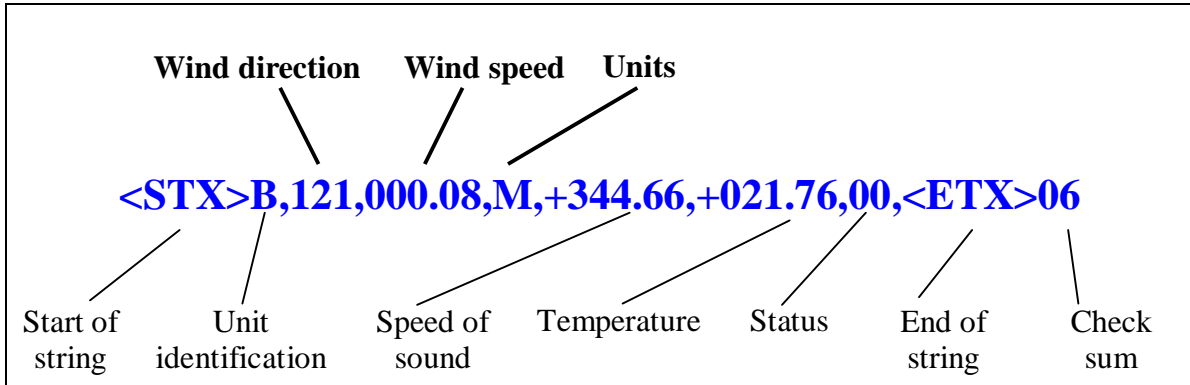

where

- Wind direction** In degrees relative to N (DDD)
- Wind speed** In increments of 0.01 units (±MMM.MM)

All other parameters *See Section 8.8 ASCII UV format*

ASCII Polled (UV and Polar)

When in the Polled mode, an output is only generated when the host system sends a Poll signal to the WindObserver consisting of the WindObserver Unit Identifier – that is, the relevant letter A – Z.

The output formats are otherwise as described above.

The commands available in this mode are:

Description	Command	WindObserver response
WindObserver Unit Identifier	A Z	Wind speed output generated
Enable Polled mode	?	(None)
Disable Polled mode	!	(None)
Request WindObserver Unit Identifier	&	A Z (as configured)
Enter Configuration mode	*<N>	CONFIGURATION MODE

Where <N> is the unit identifier, if used in a multi-drop system then it is recommended that ID's A to F and KMNP are not used as these characters can be present in the data string.

It is suggested that in polled mode the following sequence is used for every poll for information.

? Ensures that the Sensor is enabled to cover the event that a power down has occurred.

A-Z Appropriate unit designator sent to retrieve a line of data.

! Sent to disable poll mode and reduce possibility of erroneous poll generation.

When in polled mode the system will respond to the data command within 30mS with the last valid data sample as calculated by the Output rate (P Mode Setting).

If the unit is powered down after use or upon switch on then allow 3 seconds from switch on before sending poll commands.

8.9. Binary message format (UV, Polar and Tunnel)

Binary UV format

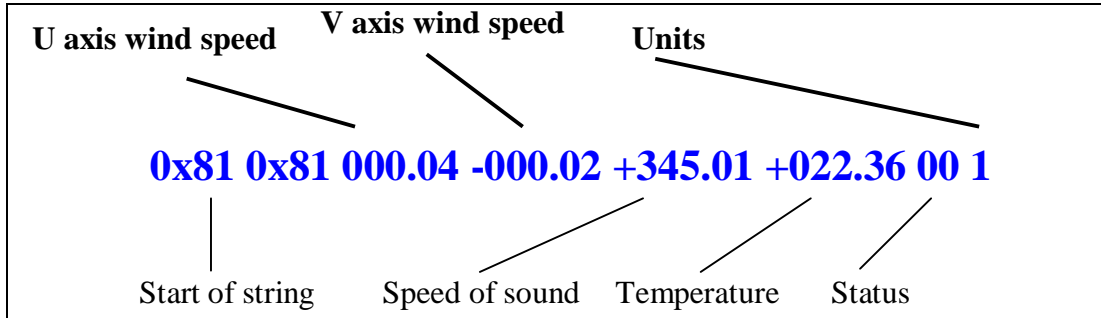

where

U axis wind speed In increments of 0.01 units ($\pm UUU.UU$)

V axis wind speed In increments of 0.01 units ($\pm VVV.VV$)

Units	Value	Units
	1	Metres per second (m/s)
	2	Knots (knots)
	3	Miles per hour (MPH)
	4	Kilometres per hour (kph)
	5	Feet per minute (fpm)

Start of string

Speed of sound In metres per second (if enabled)

Temperature Sonic temperature in degrees C (two's complement signed) (if enabled)

Status	Value	Status
	0	OK
	60	Heating enabled and OK
	Any other value	Warning or fault condition - see Section 10.5

8.10. NMEA Format

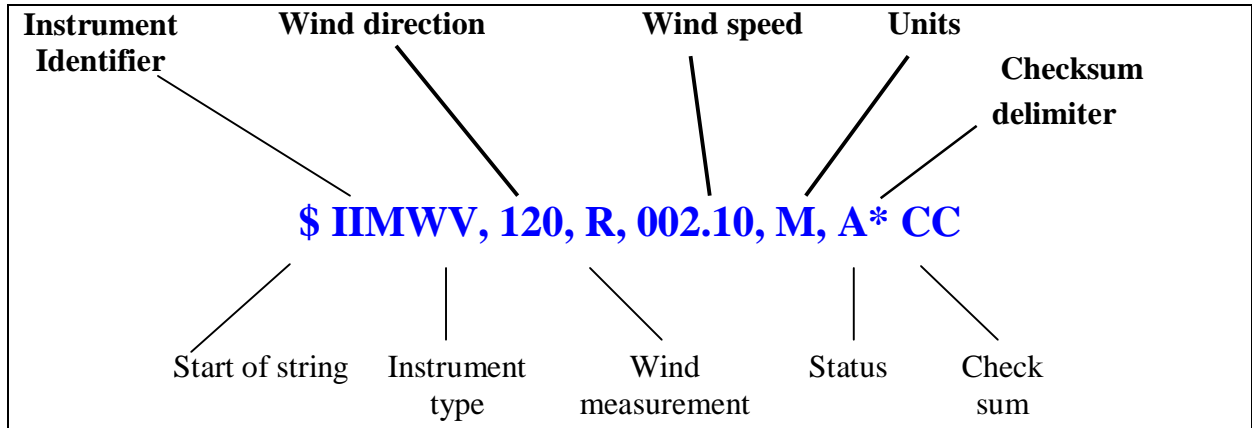

where

Wind direction	In degrees relative to N (DDD)	
Wind speed	In increments of 0.01 units (\pm MMM.MM)	
Units	M	Metres per second (m/s)
	N	Knots (knots)
	P	Miles per hour (MPH)
	K	Kilometres per hour (kph)
	F	Feet per minute (fpm)
Start of string	\$	
Instrument type	IIMWV	
Wind measurement	R	Relative wind measurement
Status	A	Acceptable measurement
	V	Void measurement
Check sum	Exclusive OR of all characters between '\$' and '*' reported as ASCII hex.	

A typical WindObserver II (Pipe Mount) configuration suitable for NMEA would be:
B2, E1, F1, G0, K1, L1, M5, O1, P1, U1.

Consult specification NMEA 0183 version 3 (available on the web) www.nmea.org for complete interface details.

9. CONFIGURING

WindCom may be used to configure WindObserver II (Pipe Mount). This is an easy to use menu-driven package, available as a free download at www.gill.co.uk.

Alternatively, you may use terminal emulator software such as HyperTerminal or Terminal.

9.1 Configuring using HyperTerminal

Note – Other terminal emulators are configured in a very similar way.

1. Decide on an available Com port that you want to use (Usually Com1).
2. Run Hypertrm.exe (Typically accessed via Start → All Programs → Accessories → Communications → Hyperterminal).
3. Create a New Connection (File → New Connection)
4. Enter a **Name** (eg WindObserver II).
5. Change ‘**Connect Using**’ to ‘Direct to Com 1’ (or other Com port as required)
6. Adjust the Port settings to match WindObserver settings. WindObserver default settings are :

Bits per second 9600

Data bits 8

Parity None

Stop bits 1

Flow Control (Handshaking) None

Click on OK and data similar to the following example will scroll on screen at the output rate:

©A, 229, 002.74, M, 00, ♥06

9.2 Entering Configuration mode

From Continuous mode

Type *

From Polled mode

Type *N - where N is the Unit Identifier.

Note - the Unit Identifier must be entered as upper-case

The WindObserver II responds with a CONFIGURATION MODE message, stops reporting wind measurements, and waits for a command (as detailed below).

9.3 Returning to Measurement mode

Type Q and press ENTER

If in **Continuous** mode, the anemometer responds with wind measurements immediately, continuing at the selected Sampling rate.

If in **Polled** mode,

- `[?]` Enables poll
- `[N]` Polls anemometer (where N is the Unit identifier entered as upper-case)
The anemometer replies with a single set of wind measurements
- `[&]` Anemometer replies with Unit identifier
- `[!]` Disables poll

Note:- If the unit is in Polled Mode it is always best to interrogate the unit for data with a `[?]` before the poll identifier to cater for the event that the power has been switched off or power interrupted.

If used in a multi drop system then it is recommended that Unit Identifiers A, B, C, D, E, F, K, M, N and P are not used.

9.4 Checking the configuration

We strongly recommend that, as a standard procedure, you use this command (`[D3]`) prior to, and after, changing any settings. It shows the current settings for all the alterable settings. We suggest you note down your settings, so that you can easily return to them.

`[Type *]` Enters Configuration Mode (from Continuous mode)

Or `[Type *N]` Enters Configuration Mode (from Polled mode)

`[Type D3 and press ENTER]` The WindObserver II responds with the current configuration settings.

The factory default settings for a heated unit are: -

```
A0 B3 C1 E1 F1 G0000 H2 J1 K1 L1 M2 NA O2 P5 T1 U1 V1 X2 Y1 Z1
```

How to change these settings is explained in the following sections.

To return to Measurement mode `[Type Q and press ENTER]`

9.5. Changing settings

To change a setting, first go into Configuration mode and then refer to the sections below. Enter the Configuration code of the new setting required, followed by `[ENTER]`.

If successful, the new setting will be echoed back as a message by the WindObserver II (Pipe Mount).

For example, to change the message format to NMEA, enter `[Type M5 and press ENTER]`. The WindObserver II (Pipe Mount) will reply with `[M5]`. When the unit is returned to the Measurement mode `[Type Q and press ENTER]`, it will be in NMEA format.

Note : The factory-set (default) settings are shown in **bold** in the following sections.

9.6. Configuration Settings

Ax – Speed of Sound (SOS) and Temperature

Setting	Configuration code
Disable both	A0
Report SOS	A1
Report Sonic temperature	A2
Report SOS and Sonic temperature	A3

Note that neither of these parameters is available in Tunnel or NMEA format.

BX - Baud Rate

Setting	Configuration code
2400	B1
4800	B2
9600	B3
19200	B4
38400	B5
1200	B6
300	B7

To change the Baud rate when using HyperTerminal: -
 Eg. If set to B3 (9600 baud) and it is required to set to Baud rate to B2 (4800 baud).
 Type ***** to enter Configuration Mode.
 Type **B 2** and press **ENTER**, (**Do not type any further commands at this stage**).
 Close the 9600 Baud HyperTerminal connection.
 Open HyperTerminal and set the new connection Baud Rate to 4800 baud.
 Type **B** and press **ENTER**, the letter B will be shown followed by B2
 Type **Q** and press **ENTER**, data will scroll at the new baud rate.

Cx – Not Applicable

Dx – Diagnostic and Configuration Command

Item	Command code	Typical response
Type and serial No.	D1	E000694
Software version	D2	2.07
Unit configuration	D3	current configuration : A0 B3 C1 E1 F1 G0000 H2 J1 K1 L1 M2 NA O2 P5 T1 U1 V1 X2 Y1 Z1
Analogue ID (if present)	D4	GI1390 fitted.
Anemometer power supply voltage	D5	+29.8
Integrity check	D6	See Para 10.6

Ex - Duplex mode

Setting	Configuration code
Full duplex	E1
Half duplex	E2

Note:- Refer also to Para 8.3 Networking Configuration details.

Fx - Data and parity options

Setting	Configuration code
8 bits, no parity, 1 stop bit	F1
8 bits, even parity, 1 stop bit	F2
8 bits, odd parity, 1 stop bit	F3
7 bits, no parity, 1 stop bit	F4
7 bits, even parity, 1 stop bit	F5
7 bits, odd parity, 1 stop bit	F6

Gx to Gxxx – Averaging (Digital Outputs Only)

Setting	Configuration code
Averaging (Default)	G0000

Enter the required averaging period in seconds as a four-figure number between 0000 and 3600.

Hx - Heating

Setting	Configuration code
Disabled	H1
Activated	H2

Heating is autonomous and requires no set-up once activated. Each transducer is heated independently and will be active when ambient temperature drops below approximately +15°C. Each transducer will de-activate when +25°C threshold is reached.

Jx – Not Applicable**Kx – NMEA Settings**

Setting	Configuration code
NMEA string “IIMWV”	K1
NMEA string “WIMWV”	K2

Lx - ASCII Message terminator

Setting	Configuration code
CR LF	L1
LF	L2

Mx to MXX – Message Format

Output format	Configuration code
ASCII UV Continuous	M1
ASCII Polar Continuous	M2
ASCII UV Polled (tri-state) *	M3
ASCII Polar Polled (tri-state) *	M4
NMEA Continuous	M5
Tunnel Continuous	M6
Binary UV Continuous	M7
Binary Polar Continuous	M8

* If units are to be networked, they MUST be given unique Unit Identifiers

Nx - Node Address

Item	Options	Command
Node Address	A... -(A to Z)	N<A>

If used in a multi-drop system then it is recommended that ID's A to F and K, M, N and P are not used, as these characters can be present in the data string.

Ox – ASCII Output Format (Output String Padding)

Setting	Configuration code
Comma Separated Variable (CSV)	O1
Fixed Field	O2

Example data strings:-

POLAR	NMEA
CSV data changing to error status code condition.	CSV data changing to error status code condition.
<input type="checkbox"/> A,235,000.77,M,00, <input type="checkbox"/> 0A	\$IIMWV,191,R,000.55,M,A*19
<input type="checkbox"/> A,,,M,04, <input type="checkbox"/> 24	\$IIMWV,,R,,M,V*29
Fixed Field data changing to error status code condition.	Fixed Field data changing to error status code condition.
<input type="checkbox"/> A,266,000.73,M,00, <input type="checkbox"/> 08	\$IIMWV,191,R,000.55,M,A*19
<input type="checkbox"/> A,999,999.99,M,04, <input type="checkbox"/> 0A	\$IIMWV,999,R,999.99,M,V*07

Px - Output rate

Outputs per second	1	2	4	5	8	10
Configuration code	P1	P3	P2	P4	P5	P6

Q – Measurement Mode

See Section 9.3.

Tx – Not Applicable.**Ux – Digital Output Units**

Units	metres/sec (m/s)	knots (knots)	miles/hour (mph)	kilometre/hour (kph)	feet/minute (fpm)
Configuration code	U1	U2	U3	U4	U5

Vx - Vertical Output Padding

Setting	Configuration code
Disable vertical output padding	V1
Enable vertical output padding	V2

Xx - 45° Alignment Offset/Inverted Operation.

Setting	Configuration code	Notes
Align U axis with transducer axis	X1	X1. Aligns U axis with North/South axis.
Align U axis +45° to transducer axis	X2	X2. This re-aligns both U & V and polar by 45°.
Reverses Polar Direction	X3	X3 reverses reported polar direction to allow the instrument to be mounted upside down. N.B. Does NOT affect UV alignment (Mode 1, 3).
Align @ 45° from North	X4	X4 set polar alignment at 45 degrees from North when instrument is mounted upside down. Does not affect UV alignment (Mode 1,3).

Figure 4 shows the polarity of U and V if the wind components along the U and V axis are blowing in the direction of the respective arrows.

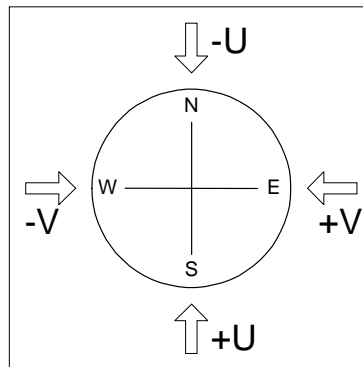

Figure 4 UV Polarity

Yx - Not Applicable.

Zx – Not Applicable.

10. MAINTENANCE & FAULT-FINDING

10.1. Cleaning

When installing the unit, handle with lint free gloves and degrease the unit to reduce the build up of deposits.

If there is any build up of deposit on the unit, it should be gently cleaned with a cloth, moistened with soft detergent. Solvents should not be used, and care should be taken to avoid scratching any surfaces. The unit must be allowed to defrost naturally after being exposed to snow or icy conditions, do NOT attempt to remove ice or snow with a tool.

Do NOT remove black “rubber” transducer caps.

10.2. Servicing

There are no moving parts or user-serviceable parts requiring routine maintenance.

Opening the unit or breaking the security seal will void the warranty and the calibration.

In the event of failure, prior to returning the unit to your authorised Gill distributor, it is recommended that:

- All cables and connectors are checked for continuity, bad contacts, corrosion etc.
- A bench test is carried out as described in Section 10.6.
- You contact your supplier for advice

10.3. Fault-finding

Symptom	Solution
No output	<p>Check DC power to WindObserver II (Pipe Mount), cable and connections.</p> <p>Check comms settings of WindObserver II (Pipe Mount) (as detailed in Section 9) and host system match, including correct Com port</p> <p>Check unit is in Continuous mode</p> <p>Check that in-line communication devices are wired correctly.</p> <p>NOTE: It is usual for Anemometer TX + to be connected to converter device RX +</p>
Corrupted output	<p>Check comms settings of WindObserver II (Pipe Mount) and host system match.</p> <p>Try a slower baud rate.</p> <p>Check cable lengths and type of cable.</p>
One way communication	Check wiring is in accordance with the manual.
Failed / Incorrect WindObserver II (Pipe Mount) output, data invalid flag	Check that transducer path is not blocked

10.4. Returning unit

If the unit has to be returned, it should be carefully packed in the original packaging and returned to your authorised Gill distributor, with a full description of the fault condition.

10.5. Status (error) codes

The Status code is sent as part of each wind measurement message.

Code	Status	Condition
00	OK	Sufficient samples in average period
60	OK and heating enabled	Sufficient samples in average period
A	OK	NMEA data valid
01	Axis 1 failed	Insufficient samples in average period on U axis
02	Axis 2 failed	Insufficient samples in average period on V axis
04	Axis 1 and 2 failed	Insufficient samples in average period on both axes
08	NVM error	NVM checksum failed
09	ROM error	ROM checksum failed
10	System gain at max.	Inaccurate results likely
50	Marginal system gain	Results OK, but marginal operation
51	Measurement average building	
62	Heating current tripped or electronic failure	
63	Thermistor open circuit	
65	Heating element open circuit	
V	NMEA data invalid	

10.6. Bench test

Couple the WindObserver II (Pipe Mount) to the host system and power supply, using a known working test cable.

Check that the unit is correctly configured by going into Configuration mode and using [D3](#). See Section 9.3 *Checking the configuration*.

Check for normal output data, and that the Status Code is OK – 00, 60 or A (for NMEA format).

If the status code is other than these, refer to Section 10.5 Status (error) codes.

Use an office fan or similar to check that the unit is sensing wind, turning the unit to simulate changing wind direction and to check that both axes are functioning.

Note that this is a quick functional test. There are no calibration adjustments; the unit is designed NOT to require re-calibration within its lifetime. Gill has provided an Integrity Check, see next page for details.

Integrity Check Chamber (ICC)

The software to perform the Integrity Check (IC) is incorporated in the latest WindObserver II (Pipe Mount).

The IC is designed to:

1. Identify any gross changes in the head geometry that would affect the performance.
2. Provide a zero wind environment to confirm the WindObserver II (Pipe Mount) zero calibration.

The ICC has been designed to be used in an indoor still air environment with an ambient temperature between 17°C and 23°C. When conducting the test it is important that the ICC is assembled on to the WindObserver II (Pipe Mount) head and not touched or moved during the test.

This test is only valid if undertaken with an ICC purchased from Gill.

Integrity & Zero Wind Check

Zero Wind Check

Configure your PC to run HyperTerminal and assemble the ICC by inserting the reflector cases and the two halves of the ICC onto the WindObserver II (Pipe Mount). The ICC must be retained using the strips provided. Then:

1. Ensure that the WindObserver II (Pipe Mount) is set in factory default mode. For Factory default settings see section 9.4.
2. Enter Measurement Mode and Record/View data

In still air wind speed measurements should not exceed 0.03m/s. If wind speed exceeds 0.03m/s contact Gill Instruments.

Integrity Check

Ensure the ICC is assembled correctly on the WindObserver II (Pipe Mount). Using HyperTerminal, enter Configuration Mode as described in Section 9.

Enter D6.

A typical report as shown below will be displayed.

```
ALIGNMENT LIMITS: U=2417,2517
                  V=2369,2469
ALIGNMENT U:2467 *PASS*
ALIGNMENT V:2419 *PASS*
D6
```

If Refer to Manual is shown check test temperature conditions are 17 to 23 deg C and tested under zero wind conditions.

If there has been no significant changes to The WindObserver II (Pipe Mount) head configuration then *PASS* will confirm correct operation.

Alterations to the head geometry will result in a *FAIL* or Insufficient Samples message. If this occurs please contact Gill Instruments.

11. APPENDICES

11.1. Glossary & Abbreviations

Item	Meaning
CAL	Calibration
CR	Carriage Return
CRLF	Carriage Return Line Feed
CSV	Comma Separated Variable
ENG	Engineering
ESC	ESCape key on keyboard used to stop any process that is being executed
ETX	End of string character
FAC	Factory
fpm	Feet per minute
GND	GrouND
HEX	HEXadecimal
I/P	InPut
IP66	Protection Classification
KPH	Kilometres per Hour
LF	Line Feed
m/s	Metres per second
MAG	MAGNitude - scalar reference to wind speed
MAX	MAXimum
MPH	Miles per Hour
NEMA	National Electrical Manufacturers Association
NMEA 0183 (version 3)	National Marine Electronics Association standard for interfacing marine electronic navigational devices
No:	Number
NVM	Non-Volatile Memory
O/P	Output
PC	IBM compatible Personal Computer
PCB	Printed Circuit Board
POR	Power On Reset
PROCOMM	Terminal emulator software package
ROM	Read Only Memory
RS232	Communications standard

Item	Meaning
RS422	Communications standard
RS485	Communications standard
RTS	Request To Send
RX	Receive
RXD	Received Data
S/W	SoftWare
SOS	Speed Of Sound
SEC	SECond
STX	Start of string character
TERM	TERMinal
TX	Transmit
TXD	Transmitted Data
+VE	Positive
-VE	Negative
WindCom	Gill software used to configure WindObserver II (Pipe Mount)
WRT	With Respect To

11.2. Guarantee

For terms of guarantee contact your supplier.

Warranty is void if the red security seal covering base nuts is damaged or broken, or the transducer caps have been damaged.

11.3. Principle of operation

The WindObserver II (Pipe Mount) measures the times taken for an ultrasonic pulse of sound to travel from the North transducer to the South transducer, and compares it with the time for a pulse to travel from S to N transducer. Likewise times are compared between West and East, and E and W transducer.

If, for example, a North wind is blowing, then the time taken for the pulse to travel from N to S will be faster than from S to N, whereas the W to E, and E to W times will be the same. The wind speed and direction (and the speed of sound) can then be calculated from the differences in the times of flight on each axis. This calculation is independent of factors such as temperature.

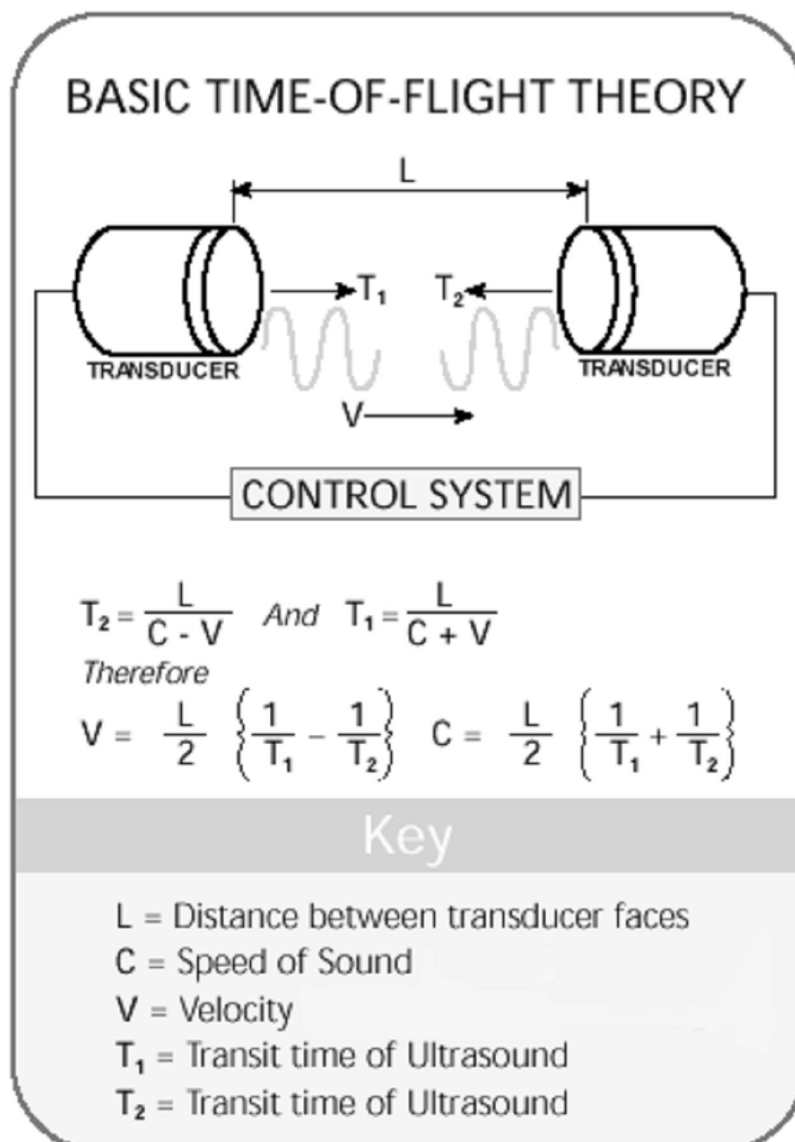



11.4. Electrical Conformity

EC DECLARATION OF CONFORMITY ACCORDING TO COUNCIL DIRECTIVE 89/336/EEC

We, Gill Instruments Ltd., declare our sole responsibility that the products:

- WindObserverII Ultrasonic Anemometer (Heated Variant)**
- WindObserverII Ultrasonic Anemometer (Heated with Analogue Outputs Variant)**
- WindObserverII Ultrasonic Anemometer (Non-Heated Variant)**
- WindObserverII Ultrasonic Anemometer (Non-Heated with Analogue OutputsVariant)**

Manufactured by:

Gill Instruments Ltd

Saltmarsh Park
67 Gosport Street
Lymington, SO41 9EG

to which this declaration relates, are in conformity with the protection requirements of Council Directive 89/336/EEC on the approximation of the laws relating to electromagnetic compatibility.

This Declaration of Conformity is based upon compliance of the product with the following harmonized standards:

EN60945:2002

EN61326:2006

Emissions	Using	EN60945
Immunity	Using	EN61000-4-2 to EN61000-4-5 EN61000-4-6 (Excluding 150kHz to 200kHz Conducted Immunity) EN61000-4-11

A handwritten signature in black ink that reads "A.C.R. Stickland". The signature is written in a cursive style.

Signed by:

A.C.R. Stickland – Director

Date of issue: 16/10/2008

Place of issue: Gill Instruments Ltd
Saltmarsh Park
67 Gosport Street
Lymington, SO41 9EG

